



# JABCON CONSULTANTS

Master Planning/Urban planning

Architecture

Real Estate advisory

Interior Design

Project Management

Bid process Management

Sustainable Design



Creating  
Spaces

**Head Office - JABCON CONSULTANTS, C/O**  
Progressive Point, 3<sup>rd</sup> Floor Off No. 318  
Near Whole Sale Fruit Market, New Dhamtari Road,  
Raipur (C.G) , 492001  
+91-8120022552

**Project office - C/O Hakimi Arcade,**  
3<sup>rd</sup> Floor Off No. 301 OCM Chowk  
Raipur, (C.G), 492001

**Project office - C/O Silver tower, First Floor,**  
Deepak Chowk, Akola (M.H) 440001

Website-[www.jabconconsultants.in](http://www.jabconconsultants.in)  
Email-[jabconconsultants@gmail.com](mailto:jabconconsultants@gmail.com)  
-[mustufa3@gmail.com](mailto:mustufa3@gmail.com)



इलेक्ट्रॉनिक आवेदन दिनांक - 01/01/2015

चॉइस एजेंट - अनिल आसुदानी

चॉइस केन्द्र - महावीर कम्प्यूटर बैरन बाज़ार, ओ सी एम चौक, रायपुर

आवेदन संदर्भ क्रमांक - 0212011500000014



छत्तीसगढ़ शासन  
रायपुर नगर निगम

( प्रारूप "ग" )

( नियम 3 (3) देखिये )

( छत्तीसगढ़ दुकान एवं स्थापना अधिनियम, 1958 )  
भाग ( क )

दुकान एवं स्थापना के पंजीयन का प्रमाण पत्र

- |   |   |
|---|---|
| 1. आवेदन संदर्भ क्रमांक   | : 0212011500000014  |
| 2. पंजीयन चिन्ह का क्रमांक  | : 2015000083/RPR/S/2015   |
| 3. दुकान एवं स्थापना का नाम   | : JABCON CONSULTANTS  |
| 4. दुकान एवं स्थापना का डाक संबंधी पूरा पता                                   | : 318 प्रोग्रेसिव पार्क, लालपुर, रायपुर वार्ड नं. - 51, रविन्द्र नाथ टैगोर रायपुर |
| 5. किये जाने वाले कारोबार, व्यापार, या धंधे का प्रकार                         | : दुकान   |
| 6. कारोबार का स्वरूप  | : कंसलटेंट्स आफिस   |
| 7. दुकान एवं स्थापना में नियोजक के रूप में हित रखने वाले व्यक्ति यों का विवरण |   |

क्र.	नाम	पिता/पति का नाम	पद
1	मुस्तफा ज़मील अहमद	जमील अहमद	संचालक

8. स्थापना में नियोजन के रूप में हित रखने वाले अन्य व्यक्ति का नाम तथा पद, राज्य में उसके पते सहित ( यदि कोई हो तो ) :

9. छुट्टी का दिन : रविवार

10. नौकरो की कुल संख्या	पुरुष	स्त्री	योग
वयस्क	1	1	2
युवा व्यक्ति	0	0	0
योग	1	1	2

यह प्रमाणित किया जाता है कि स्थापना, जिसके कि ब्यौरे ऊपर दिये गये हैं, छत्तीसगढ़ दुकान तथा स्थापना अधिनियम 1958 ( क्रमांक 25, सन् 1958 ) के अधीन आज दिनांक 08/01/2015 को पंजीयित की गई है।

यह पंजीयन प्रमाण पत्र 31/12/2019 तक समाप्त होने वाले वर्ष के लिए वैध है।

पंजीयन दिनांक

08/01/2015

डिजिटल हस्ताक्षरित

बलदाऊ वर्मा

सहायक राजस्व अधिकारी

"दुकान / प्रतिष्ठान में डस्टबीन रखा जाना अनिवार्य है"

- यह प्रमाण पत्र इलेक्ट्रॉनिक प्रमाण पत्र की मुद्रित प्रतिलिपि है जिसे सूचना प्रौद्योगिकी अधिनियम 2000 के अन्तर्गत छत्तीसगढ़ नागरिक सेवा (इलेक्ट्रॉनिक अधिशासन) नियम 2003 के द्वारा मान्यता दी गई है।
- इस इलेक्ट्रॉनिक प्रमाण पत्र का सक्षम व क्षेत्राधिकार वाले मुख्य कार्यापालन अधिकारी, रायपुर नगर निगम के डिजिटल हस्ताक्षर से अभिप्रमाणित होने का सत्यापन मेरे द्वारा किया गया है तथा इस पर मुद्रित जानकारी उक्त इलेक्ट्रॉनिक प्रमाण पत्र में निहित है।
- आवेदन संदर्भ क्रमांक का उपयोग कर इस प्रमाण पत्र की वैधता बाबत जानकारी [www.choice.gov.in](http://www.choice.gov.in) वेब साईट अथवा दूरभाष क्रमांक (0771) 4080106 से प्राप्त की जा सकती है।
- यदि इस प्रमाण पत्र को किसी प्राधिकारी अथवा कार्यालय द्वारा ग्राह्य करने से इन्कार किया जाता है तो इसकी सूचना निकट के चॉइस केन्द्र को दें।

मुद्रण दिनांक - 30/01/2015

सधन्यवाद से 5/- रुपये प्रमाण-पत्र शुल्क प्राप्त किया।

उपरोक्त प्रमाण पत्र प्राप्त किया

मुद्रण दिनांक - 30/01/2015

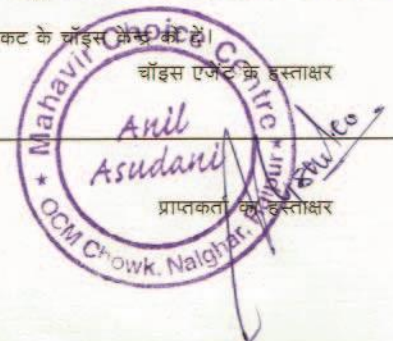



## कार्यालय नगर पालिक निगम, रायपुर

रायपुर, दिनांक... 11573  
31/12/2014

# अनुज्ञप्ति (लायसेंस )

रायपुर नगर पालिक निगम भयप्रद तथा उद्वेजक व्यापार एवं कारखाना उपविधि 1992 की अनुसूची ..... ane ..... के अधीन श्री Mustafa Jamil Ahmed ..... आत्मज श्री ..... फर्म JABCON CONSULTANTS ..... को स्थान Consultants (office) ..... पर व्यवसाय करने की अनुमति दी जाती है। अनुज्ञप्ति दिनांक 31/3/2015 ..... तक प्रभावशील रहेगी।

सम्बन्धित व्यवसाय के लिए उपविधि में प्रदत्त शर्तों का पालन करना होगा। इससे उल्लंघन पाये जाने पर अनुज्ञप्ति निरस्त कर दी जायेगी तथा वस्तुएं जप्त कर कार्यवाही क की जायेगी इसके अतिरिक्त न्यायालयीन प्रकरण दर्ज किया जा सकेगा।

भूमि भवन के स्वत्व, स्वामित्व सम्बन्धी किसी विवाद में इस अनुज्ञप्ति का कोई न्यायिक मूल्य नहीं होगा।

स्वहित में राष्ट्र हित में ऊर्जा बचायें

हस्ताक्षर अधिकारी,  
अनुज्ञप्ति अधिकारी  
नगर पालिक निगम, रायपुर (छ.ग.)

# Council of Architecture

(Incorporated under the Architects Act, 1972)



India Habitat Centre  
Core 6-A, 1st Floor  
Lodhi Road  
New Delhi - 110 003 India  
Phones } 91-11-2464 8415  
          } 91-11-2465 4172  
Fax : 91-11-2464 7746  
E-mail : coa@ndf.vsnl.net.in  
Web : www.coa-india.org

Ref.No. CA/2008/41766

Date : 01/02/2008

## TO WHOMSOEVER IT MAY CONCERN

This is to certify that **Shri MUSTUFA JAMEEL AHMED**, an architect registered with the Council of Architecture vide Registration Number **CA/2008/41766**, has availed of One time Payment of Renewal Fee, details of which are as under :

1. Vide Receipt No. C-935 dated 22.1.08 : **Rs. 5,000/-**
2. Adjusted advance payment of renewal fee made vide : Rs. \_\_\_\_\_  
Receipt No. \_\_\_\_\_ dated \_\_\_\_\_ for the  
year(s) 2008 onwards (2008 to \_\_\_\_\_ )
3. Adjusted arrears (following revision of renewal fee) : Rs. \_\_\_\_\_  
paid, vide Receipt No. \_\_\_\_\_ dated  
\_\_\_\_\_, towards advance payment of renewal fee  
for the year(s) 2008 onwards (2008 to \_\_\_\_\_ )
4. Payment received (i.e. credit adjustable) vide Receipt : Rs. \_\_\_\_\_  
No. \_\_\_\_\_ dated \_\_\_\_\_

TOTAL :

**Rs. 5,000/-**

For the time being, the Certificate's validity has been extended upto and including the 31st day of December, 2019. The period of validity of the Certificate of Registration beyond 31.12.2019 should be got extended (i.e. endorsement), on your own, from the Registrar of the Council without making any further payment therefor.

# Council of Architecture

## Certificate of Registration

This is to certify that the name of

Shri **MUSTUFA JAMEEL AHMED**

has been entered in the register and his Registration No. is

**CA/2008/41766**

This certificate is valid from the first  
day of **February 2008** to the thirty-first  
day of **December 2009** inclusive.

List of Additional Qualifications :

Given under the common Seal of the Council of Architecture,

### Renewals

Valid upto

Signature of  
Registrar

31.12.2019

Vinod Kumar  
1-2-2008

31.12.2029

M. Ahmed  
16-1-14

this first day of **February, 2008**

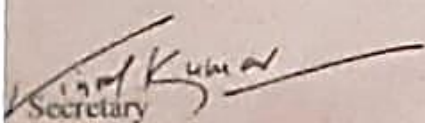
  
Secretary

  
President

# FIRM FINANCIAL DETAILS



**JABCON CONSULTANTS**

आयकर विभाग  
INCOME TAX DEPARTMENT



भारत सरकार  
GOVT. OF INDIA



स्थायी लेखा संख्या कार्ड  
Permanent Account Number Card  
AHOPA8472B



नाम / Name  
MUSTUFA AHMED

पिता का नाम / Father's Name  
JAMEEL AHMED

जन्म की तारीख /  
Date of Birth  
29/05/1980

  
हस्ताक्षर / Signature

08022024



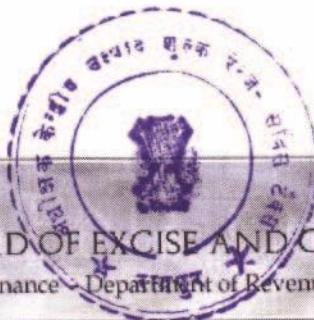

# CENTRAL BOARD OF EXCISE AND CUSTOMS

Ministry of Finance - Department of Revenue

## FORM ST-2

Shri/Ms. Mustufa jameel ahmed,A-19, 5th Floor Wall Fort Inclave Lal Pur Raipur C.G. having undertaken to comply with the conditions prescribed in Chapter V of the Finance Act,1994 read with the Service Tax Rules,1994,and any orders issued thereunder is hereby certified to have been registered with the Central Excise Department.The Service Tax Code and other details are mentioned hereunder.

<b>Name :</b>	Mustufa jameel ahmed
<b>Address :</b>	A-19, 5th Floor Wall Fort Inclave Lal Pur Raipur C.G.
<b>PAN No :</b>	AHOPA8472B
<b>Name as in PAN :</b>	MUSTUFA JAMEEL AHMED
<b>Nature of registration :</b>	Registration of a single premise
<b>Service Tax Code(Registration Number) :</b>	AHOPA8472BSD001
<b>Taxable services :</b>	Architect services

### ADDRESS OF BUISNESS PREMISES

<b>Name Of Premises/Building :</b>	A-19 5th Floor Wall Fort Inclave	<b>Flat / Door / Block No :</b>	A-19 5th Floor Wall Fort Inclave
<b>Road / Street / Lane :</b>		<b>Village / Area / Lane :</b>	Lalpur
<b>Block / Taluk / Sub-Division / Town :</b>	Lal pur	<b>Post Office :</b>	Lalpur
<b>City / District :</b>	Raipur	<b>State / Union Territory :</b>	CHHATTISGARH
<b>PIN :</b>	492001	<b>Phone Number-1 :</b>	8120022552
<b>Phone Number-2 :</b>		<b>Fax Number-1 :</b>	
<b>Fax Number 2 :</b>		<b>Email Address :</b>	mustufa3@gmail.com
<b>Premises Code :</b>	350211A001		

SI No	Types of Services	Accounting Codes		
		Tax Collection	Other Receipts (Interest)	Penalties
1	Architect services	00440072	00440073	

### CESSES

1	EDUCATION CESS	00440298	00440299	00441486
2	SECONDARY AND HIGHER EDUCATION CESS	00440426	00440427	00441487

### Note :

- In case the registrant starts providing any other taxable service (other than those mentioned above), he shall intimate the department.
- In case the registrant starts billing from other premises (other than those mentioned above), he shall intimate the department.
- These intimations and any other information which registrant wishes to bring to the notice of the department can be submitted on-line by the registrant after logging on to web-site.
- This registration certificate is not transferable.
- List of Accounting Codes is Enclosed.These may invariably be furnished in the challan at the time of making payment of service tax.

Remarks :

Upload File :

Date of Issue of Original ST-2 : 09/07/2013

Name and Signature of Central Excise Officer  
With Official Seal

SUPERINTENDENT

3



Government of India  
Form GST REG-06  
[See Rule 10(1)]

Registration Certificate

Registration Number : 22AHOPA8472B2ZM

1.	Legal Name	MUSTUFA JAMEEL AHMED			
2.	Trade Name, if any	JABCON CONSULTANTS			
3.	Constitution of Business	Proprietorship			
4.	Address of Principal Place of Business	3RD FLOOR, 318, PROGRESSIVE POINT BUILDING, LALPUR, LALPUR, Raipur, Chhattisgarh, 492001			
5.	Date of Liability	28/09/2019			
6.	Period of Validity	From	28/09/2019	To	Not Applicable
7.	Type of Registration	Regular			
8.	Particulars of Approving Authority				
Signature					
Name					
Designation					
Jurisdictional Office					
9.	Date of issue of Certificate	05/10/2019			
Note: The registration certificate is required to be prominently displayed at all places of business in the State.					

# AWARDS AND ACHIEVEMENTS



**JABCON CONSULTANTS**



# GLOBAL LEADERSHIP SUMMIT & AWARDS - 2022 GOA, INDIA.

*Congratulations for*  
**BEST CREATIVE ARCHITECT OF CHHATTISGARH AWARD - 2022**



**AR. MUSTUFA AHMED**  
 CHIEF ARCHITECT & PLANNER - JABCON CONSULTANTS  
 RAIPUR, CHHATTISGARH (INDIA).



**Date : 29th May, 2022**

**Venue : Hotel - Fidalgo, Panaji, Goa, India.**

**+91-9891273058**



**+91-9818035977**



Certainly, some projects are dear even to a busy architect because of the 'story' that they carry and the impact that they have on society. For Ar. Mustafa, the Calderys DAV School at Katni is something close to this. School design, as they say, is as much about those 'wonder years' as it is about the physical planning. The DAV Schools significant with good reason. Firstly, the school, funded by the international Imerys/Calderys group, was completed in a surprisingly reasonable budget keeping in mind all the criteria of a climate-friendly plan, Vaastu principles and a sound landscape plantation layout. Secondly, with part of the earlier 25 year old building to be retained on the 1.48 acre plot, this new structure had to serve as a fitting sibling. As it turned out, it was a happy ever after ending; all spaces are planned with due attention to response of users- whether students or teachers. While the high level of detailed drawings, bubble diagram and other design processes makes it appear like a corporate project, it is the simple design with light, enjoyable spaces and easy logical circulation that makes this a school where students want to come!



# DESIGN DEBATE INVITATION



ARCHITECT and INTERIORS INDIA

#AIDesignDebate

**Design DEBATE**  
Raipur Edition

THE FUTURE OF DESIGN  
DEBATING TRADITION VS TECHNOLOGY

MEET OUR PANELLIST

**MUSTUFA AHMED**  
Chief Architect Planner, JABCON Consultants  
& Professor, ITM University

A promotional graphic for the event. It features the event's logo and title, a hashtag, and a portrait of one of the panelists, Mustafa Ahmed. The text describes the event's theme and provides information about the speaker.

17 MARCH, 2023 | 05 PM ONWARDS | HYATT RAIPUR

Associate Partner  
**KEI**  
Wires & Cables

Exhibit Partners  
**DURO** | küche7

Acoustics Partner  
**KNAUFCEILING**  
Solutions

Knowledge Partner  
**OHMATTOSARAH**  
CHAPTER

**REGISTER NOW**



# IIA INVITATION AS GUEST SPEAKER AT RAJNANGAON SUB CHAPTER INAUGURATION



Architects united: A moment captured as the newly-formed Rajnandgaon Sub-centre of IIA Chhattisgarh celebrates its inception

One of the most notable aspects of the occasion was the attendance of esteemed keynote lecturers, Ar. R.K. Patel and Ar. Mustafa Ahmed. Their distinguished attendance infused the ceremony with an air of prestige, and their perceptive lectures made a lasting impression on the architects in attendance. Ar. Mustafa Ahmed and Ar. R.K. Patel presented their outstanding work, recounting insights and knowledge gained during their distinguished professional trajectories. Not only did their presentations exhibit remarkable architectural prowess, but they also provided the architects in attendance with a wealth of inspiration. The selection of speakers exemplified the dedication of the IIA Chhattisgarh chapter to showcasing visionaries and leaders in the field, facilitating the interchange of knowledge, and

## IIA CHHATTISGARH CHAPTER

IIA Chhattisgarh Chapter reached a noteworthy milestone in its endeavour to extend its influence and scope throughout the state when the second Council Meeting in September 2023 in Bhubaneswar approved the Sub-Centre body formation proposal. This occasion signified a critical juncture for the regional architectural community, as it facilitated the construction of the Rajnandgaon Sub-Centre. As a result of the Council Meeting's approval, the General Body Meeting (GBM) that took place on the 8<sup>th</sup> provided an opportunity for additional discussions and strategic preparations. The elaborate installation and oath-taking ceremony that followed served as a symbolic indication of the Rajnandgaon Sub-Centre's newly established authority. This occurrence not only established the structure in its formal form, but also provided the groundwork for a thriving centre of architectural endeavours in the area. The festivities served as a demonstration of the IIA Chhattisgarh chapter's dedication and zeal in cultivating a robust architectural community that extended well beyond its principal location. The installation and oath-taking ceremony served a purpose beyond mere protocol; they symbolized the combined aspiration and resolve to enhance the architectural milieu in Rajnandgaon.



Architects united: A moment captured as the newly-formed Rajnandgaon Sub-centre of IIA Chhattisgarh celebrates its inception

One of the most notable aspects of the occasion was the attendance of esteemed keynote lecturers, Ar. R.K. Patel and Ar. Mustafa Ahmed. Their distinguished attendance infused the ceremony with an air of prestige, and their perceptive lectures made a lasting impression on the architects in attendance. Ar. Mustafa Ahmed and Ar. R.K. Patel presented their outstanding work, recounting insights and knowledge gained during their distinguished professional trajectories. Not only did their presentations exhibit remarkable architectural prowess, but they also provided the architects in attendance with a wealth of inspiration. The selection of speakers exemplified the dedication of the IIA Chhattisgarh chapter to showcasing visionaries and leaders in the field, facilitating the interchange of knowledge, and

cultivating an architectural community culture that promotes ongoing education. The chapter actively promotes a culture of excellence in architecture and aids in the professional development of its members through the organisation of such events.

The ensuing celebratory event and the successful establishment of the Rajnandgaon Sub-Centre demonstrated the Chhattisgarh Chapter of the IIA's commitment to promoting architectural activities and raising awareness throughout the state. This strategic expansion serves as an indication of the Chapter's increasing influence and a proactive measure to decentralise resources and opportunities for architects in various regions. In summary, the installation and oath-taking ceremony, which coincided with the sanction of the Sub-Centre body formation, signify a momentous milestone in the IIA Chhattisgarh chapter's history. The architect attendees' fervour and the distinguished speakers' attendance served to highlight the Rajnandgaon Sub-Centre's vitality and potential. The Chapter is well positioned to significantly influence the architectural discourse of Chhattisgarh, promote cooperation, and serve as a source of inspiration for aspiring architects in the state as it further expands its influence.

## IIA HIMACHAL PRADESH CHAPTER

**IIA Himachal Pradesh Chapter celebrated Bal Divas at Nagchalla Mandi, Himachal Pradesh.**

IIA Himachal Pradesh Chapter celebrated Bal Divas at Nagchalla Mandi Himachal Pradesh on 11 November 2023 by visiting cooperative schools of specially-abled students. Ar. Nand Lal Chandel, Chairman IIA Himachal Pradesh Chapter, presided as Chief Guest during this function, where he also distributed various toys and other useful materials to the specially-abled students.



Ar. Nandlal Chandel giving away the prizes

JABCON invited as guest speaker to on inauguration ceremony of IIA Rajnangaon sub chapter in Chhattisgarh and this event was also mentioned and published in IIA central general.

# TOP STAR ACHIEVER MALE AWARDS BY IIID RAIPUR FOR INTERIOR DESIGN SERVICES





# DESIGN EXCELLENCE AWARD 2018- 2019 BY IIID



# CERTIFICATIONS & WORKSHOPS



**JABCON CONSULTANTS**

## METROPOLIZACIÓN Y CENTRO HISTÓRICO

### TALLER INTERNACIONAL DE URBANISMO EN PUEBLA

26 MAYO AL 9 DE JUNIO 2012



H. Puebla de Zaragoza, a 25 de mayo de 2012

**AHMED MUSTUFA**  
PARTICIPANTE DE INDIA  
PRESENTE.

A nombre del Presidente Municipal de Puebla, Eduardo Rivera Pérez, tenemos el gusto de darle la más cordial bienvenida al **Taller Internacional de Urbanismo "Metropolización y Centro Histórico"**, que se realizará del 26 de mayo al 9 de junio, en coordinación con la Embajada de Francia en México, *Les Ateliers Internationaux de Maîtrise d'Ouvre Urbaine*, la Secretaría de Desarrollo Social del Gobierno Federal y Citelum, con el apoyo del Gobierno del Estado, la Universidad de las Américas Puebla y la participación de numerosos actores académicos, empresariales y de gobierno.

Es un honor saludarle desde el corazón de la **Heroica Puebla de Zaragoza**, ciudad de museos, patrimonio religioso y experiencias inolvidables; uno de los complejos arquitectónicos y artísticos más fascinantes de México, surgido del encuentro entre el mito y la historia, declarada **Patrimonio Cultural de la Humanidad** por la UNESCO hace 25 años y que en este 2012 conmemora el 150 aniversario de la gesta heroica de 1862: la Batalla del 5 de Mayo.

Estamos convencidos de que su estancia y participación en el **Taller Internacional de Urbanismo "Metropolización y Centro Histórico"** será sin duda una experiencia significativa, donde buscaremos juntos, con inteligencia compartida, soluciones para la **Puebla que queremos**.

Reciba un abrazo fraternal.

**Pedro Ocejo Tamo**  
Secretario de  
Desarrollo Económico y Turismo

**Luis Armando Olmos Pineda**  
Coordinador General del  
Instituto Municipal de Planeación

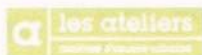



SUN-YAT-SEN  
UNIVERSITY



NORTHERN ARIZONA  
UNIVERSITY

## *Certificate of Presentation*

2007, 5th International Conference on Heritage and Tourism  
Community, Enterprise, Government & Tourists

Mustufa Ahmed

*BAO Jigang 包纪刚*

BAO Jigang, Dean, Ph.D and Professor  
School of Tourism Management  
School of Geography and Planning  
Sun Yat-sen University  
P.R.China

*Alan Lew*

Alan Lew, Professor  
Department of Geography, Planning and Recreation,  
College of Social & Behavioral Sciences  
Northern Arizona University, USA

## CERTIFICATE

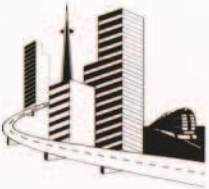

This is to certify that *Mr. Mustafa Ahmad*

presented key note speech on

*"Urban Infrastructure Scenario"*

### "NATIONAL SEMINAR ON FUTURE OF URBANIZATION"

Organized by Department of Architecture, NIT Raipur,  
and  
INTACH, Chhattisgarh  
at

**National Institute of Technology Raipur**

27<sup>th</sup> July & 28<sup>th</sup> July 2010



*Shayal*  
Coordinator

*Manish*  
Head  
Dept. of Arch.

*Rajesh*  
C.G. State Convener  
INTACH



INTACH

# MÉTROPOLISATION ET CENTRE HISTORIQUE

QUEL DÉVELOPPEMENT DURABLE ET OPÉRATIONNEL POUR LA MÉTROPOLE  
AU TRAVERS DE L'IMPLICATION DE TOUS SES ACTEURS?

François Delarue, PRÉSIDENT ADJOINT DES ATELIERS, Fernando Manzanilla Prieto, SECRÉTAIRE  
GÉNÉRAL DU GOUVERNEMENT DE L'ÉTAT DE PUEBLA, Eduardo Rivera Pérez, MAIRE DE LA VILLE DE PUEBLA.

Attestent que Mustafa Ahmed  
a participé à la session Puebla 2012 de Les Ateliers Internationaux de Maîtrise d'Oeuvre Urbaine, entre le 26 mai et le 8 juin en  
qualité de participatif PUEBLA - MEXIQUE, le 8 juin 2012.



François Delarue  
Président Adjoint des Ateliers

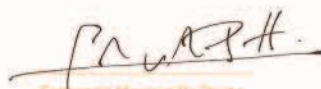

Fernando Manzanilla Prieto  
Secrétaire Général du Gouvernement  
de l'Etat de Puebla

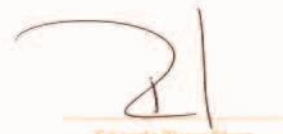

Eduardo Rivera Pérez  
Maire de la Ville de Puebla

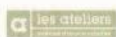



les ateliers  
maîtrise d'œuvre urbaine

International Urban Planning Workshop  
Naya Raipur, 17th - 30th November 2012

# Shaping a New capital to fit Indian life

Exploring Thresholds, Limits and in-between zones

Pierre-André Périssol, Chairman of Les Ateliers Internationaux de Maîtrise d'œuvre urbaine  
S.S. Bajaj, CEO of Naya Raipur Development Authority  
& Tony Ball, Vice President of the European New Towns Platform and Pilot cities

Certify that Mr/ ~~Ms~~ *Mustufa Ahmed*

**Participated in the International Urban planning workshop in Naya Raipur,  
17th - 30th November, 2012**

in the role of *participant*

Raipur, 30<sup>th</sup> November 2012

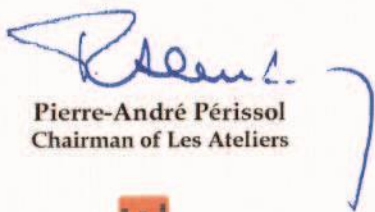
  
Pierre-André Périssol  
Chairman of Les Ateliers

  
S S Bajaj  
CEO of NRDA

  
Tony Ball  
Vice President of ENTP



# FIRM PUBLICATIONS



**JABCON CONSULTANTS**



# Jabcon Consultants

## DELIVERING END-TO-END INDUSTRIAL ARCHITECTURE DESIGN SERVICE

In modern society, the role of architecture has grown beyond its roots to set a strong footprint on future efficiency and operability of a civil structure. For critical assets like industrial units, the role of architecture is invaluable and significant. With the need to fit multiple crucial activities like storage, operation, and human movement, the quality & effectiveness of the proposed industrial design seems decisive. Furthermore, as the demand for sustainable design and statutory approval grows, an end-to-end assistance of an experienced architecture firm deems imperative. This is where Jabcon Consultants with more than one decade of experience comes into the picture.

Since inception, Jabcon Consultants has strived to evolve as a one-stop shop for its clients, delivering a wide basket of services that meets each criterion with complete diligence. Owing to this, the firm now provides an end-to-end architecture design services that involves conceptualization, designing, statutory approvals, and execution. Jabcon Consultants has also involved itself in numerous high-profile government and corporate projects, which in turn has helped the firm to gain an unmatched knowledge and experience about the segment.

"Jabcon Consultants was formed with a goal to aid the industry at a larger scale. Today, our service line is not limited to architecture service, but we also specialize in delivering a comprehensive range of services necessary for the development of large scale projects", says Mustufa Ahmed, Founder, Jabcon Consultants.

### Leading with Experience

Owing to the impeccable domain knowledge, Jabcon has successfully completed numerous critical large scale projects. Starting the list with Madhya Pradesh Nagar Nigam projects, the firm collaborated with the governments in the development of a whole new city, wherein Jabcon was in total control of designing the total site from pin to plane. The team has also played a significant part in development of the crucial Telco industrial project, Naya Raipur, wherein the firm was responsible for the designing to execution of the project. Additionally, the team played a critical role in

obtaining statutory approval at different stages. Apart from these, the firm was involved in the development of different national and international projects. For example, Jabcon was selected to deliver designs for urban townships in Mexico, the team also did several projects in China.

At an individual level, Mustufa Ahmed contains great knowledge on this segment. His deep experience of more than two decades is the center force driving the growth of Jabcon. Ahmed was amongst the selected few responsible for the development of Naya Raipur. Moreover, he is also the HOD, School of Architecture Planning & Design at ITM University.



Mustufa Ahmed, Founder

### Wide range of service

"Jabcon Consultants is away from the conventional architectural firms and we strive to deliver a wide basket of services to our client", shares Ahmed.

With years of experience, the firm now provides architectural consultancy service, urban planning, interior design, landscape planning, real estate advisory, project structure execution, techno

economic feasibility service, and more.

On top of that, Jabcon Consultants also delivers procurement services to its clients. For example- Jabcon collaborated with UMTC to deliver procurement services for the Noida BRTs project. In addition, the team has been involved in numerous procurement services at different parts of the nation.



Our service line is not limited to architecture service, but we also specialize in delivering a comprehensive range of services necessary for the development of large scale projects

Today, Jabcon Consultants has two dedicated offices at Akola, Maharashtra, and Raipur, and one part time office at Delhi. In the coming days the firm wants to level up its expertise of delivering end-to-end architectural service and establish itself as a design build firm. ||

# JABCON CONSULTANTS

**Adding detail to every Design with its leading Architectural Services**



Mustafa Ahmed,  
Founder & Chief Architect Planner

The architectural services market is expected to reach a CAGR of 4.5 percent, during the period of 2021-2026. Technology's role in architecture is omnipresent, and it is set to increase as the digital age continues to evolve. Due to fast-paced infrastructural development in various developing and developed regions in the globe, there seems to be a constant up-gradation when it comes to building design and architectural requirements. Growing construction operations across residential, commercial and at public sector is driving the market efficiently. Spearheading the same at the forefront with its quality services is Raipur based Jabcon Consultants.

Jabcon Consultants is a leading Service Provider company of Architects, Project Management, Interiors, Valuation and Urban Planning from Raipur. "We are consistently committed to the search for architecture capable of enhancing life and providing a sense of

inspiration and engagement to its inhabitants," says Mustafa Ahmed, Founder & Chief Architect Planner at Jabcon Consultants. Jabcon is a company promoted by experienced professionals with experience in designing and planning for various projects and has diversified its area into industrial venue experienced experts. Jabcon Consultants operate in an open studio environment. The firm comprises of Engineers, Architects, Planners, Landscapeist etc. and computer professionals of repute ably supported by experts in various disciplines of highest caliber.

## Services that Make a Difference

As part of its flagship offerings, Jabcon Consultants provide architectural consultancy, urban planning, interior design, landscape planning and design, real estate, project structure, and Government procurement and bid process management services. The company is skilled in creating spaces that reflect how you live and work, both functionally and aesthetically. "Adding our architect design consultation services in your project is all about having a knowledgeable partner to guide you through the process. Crafting well-designed spaces in what our designers do every day," says Mustafa. The company is also the leading service providers of Urban Design and Master Planning Services from past many years. It has gained enough experience in the industry due to which its services are ranked at the topmost position.

Jabcon Consultants also offer interior design services through which they help clients with the right colors, textures, and finishes that can tie a space together, create a specific mood, and serve as characters in the story of a particular space. "Besides, we support our clients in identify the appropriate locations for their upcoming future projects in Residential, Commercial & Industrial Locations, upgradation of the existing Equipments and the Plant & Machinery in the existing units being acquired. Identification of lease and rental properties, analysis of best use of the existing assets as well as Opportunity investigations," adds Mustafa.

Through its project structure execution and management services, Jabcon focuses on planning, implementation, communication, risk analysis and management, and quality management for its clients.



Lastly, the company is eagerly engaged in specialized services such as Bid Process Management Services which are related to all the formalities and rules followed in the bidding process. To manage bidding process in the corporate, one needs professional support by the expert who is familiar in this domain. Jabcon provides these services at market competitive rates.



**Jabcon Consultants has established itself as the major service provider for architectural consultancy, urban planning, interior design, landscape planning & design, real estate, project structure, and Government procurement & bid process management**

Over the past few years, Jabcon has handled key projects in Naya Raipur city. Chhatraighath of the government sector such as NTPC, WRII Office, Naya Raipur, and IIT

master plan and infra design services. Other than this, the company is involved as a local architect for the first Reserve Bank of India office currently being constructed from last 6 years along with principal architect Katun J Bahlbhoi Consultants. Other than this it is handling key industrial projects like Twicken industries planning design services along with service center for Maruti Suzuki including all the statutory approval and supervision in building works.

## Always Bringing its A+ Game

Jabcon Consultants has established itself as the major service provider for architectural consultancy, urban planning, interior design, landscape planning and design, real estate, project structure, and Government procurement and bid process management. It has also offered its services to international clients like Nippon Seki in Japan. Nippon had come to Jabcon for a feasibility study of model economic township. Haryana Jaijair. Based on the key report provided by Jabcon, Nippon was able to build their own plant.

In the future, the company hopes to expand its services of valuation to the banking sectors for regular lending works. It will continually work toward its vision of developing urban infra projects with sustainability.

"By leveraging the latest technology, we will continue to be the leading service provider of Architects, Project Management, Interiors, Value, Valuation and Urban Planning from Raipur," concludes Mustafa. □

# URBAN PLANNING/MASTER PLANNING EXPERIENCE OF THE FIRM



**JABCON CONSULTANTS**

**Project:** whole sale market master planning & feasibility study

**Client:** Naya Raipur Development Authority  
**Duration:** January' 2023 – November' 2023

**Location:** Nava Raipur, C.G. Layer III  
**Position:** Team Leader Architect Urban Planner

**Project Detail :**

**Scope Of Work :** Feasibility And Detail Master Planning For Whole Sale Market Development  
**Contractor On Site :** N/A  
**On Site Supervision :** N/A  
**Major Role In Project :** Feasibility Study & Master Planning & Infrastructure

Figure 1 Site Earmarked for Wholesale Commercial Highstreet Development



**PROJECT CONTOURS**

Nava Raipur Atal Nagar Vikas Pradhikaran intends to develop a **Wholesale Commercial Highstreet** in around **438.47 Hectare (1083.47 Acres)** land spread across its sector 23, 24, 34, 35 & 40

For its detailed planning, the broad scope includes, but not limited to

- Demand Assessment
- Feasibility Report
- Project Planning
- Preparation of Detailed Project Report
- Project Structuring

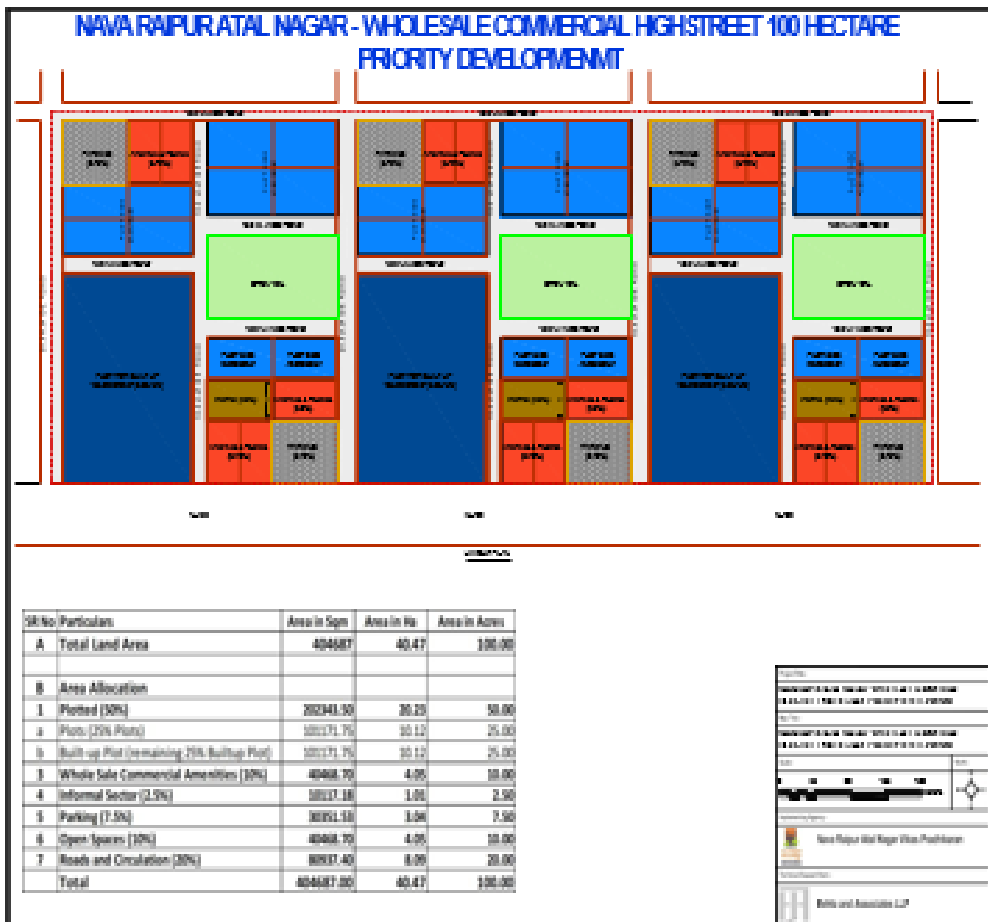

**Project:** Master Planning For Strategies Towards Sustainable Habitat Doing A Case Of Sector 17

**Client:** Naya Raipur Development Authority

**Location:** Nava Raipur, C.G.

**Duration:** September 2019 – January 2020

**Position:** Chief Architect And Planner

**Project Detail :**

**Scope Of Work:** - Master Planning And Sustainable Strategy Planning

**Major Role In Project :** - Sustainable Strategy Planning

# MASTER PLANNING FOR STRATEGIES TOWARDS SUSTAINABLE HABITATS:

A QUANTITATIVE APPROACH & URBAN ENVIRONMENT CONSIDERATIONS IN AREA BASED DEVELOPMENT PROJECT FOR SECTOR 17 NAYA RAIPUR (ATAL NAGAR)



JABCON CONSULTANTS

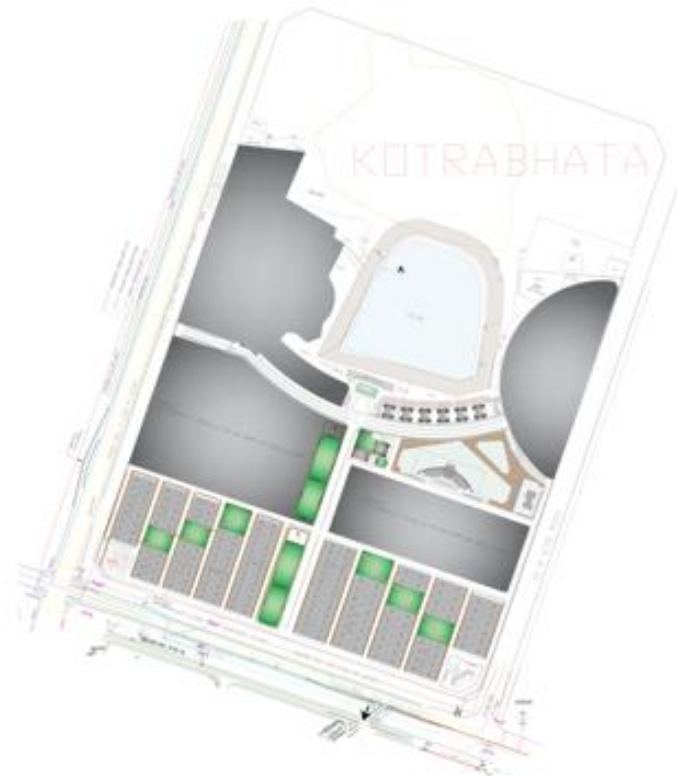

Highlighted zone currently available for planning and construction proposed for sector 17



**Project: IIIT Integrated Campus Master Planning And Building Design**

**Client: Naya Raipur Development Authority**

**Location: Atal Nagar, Nava Raipur, C.G.**

**Duration: August'2017 – Ongoing**

**Position: Consortium Master Planner & Architect**

**Project Detail :**

**Scope Of Work: - IIIT Integrated Campus Master Planning And Building Design, Nava Raipur Atal Nagar (C.G.)**

**Contractor On Site: - Raipur Construction Pvt. Ltd.**

**On Site Supervision: - Pmc: Mars Planning & Consultant**

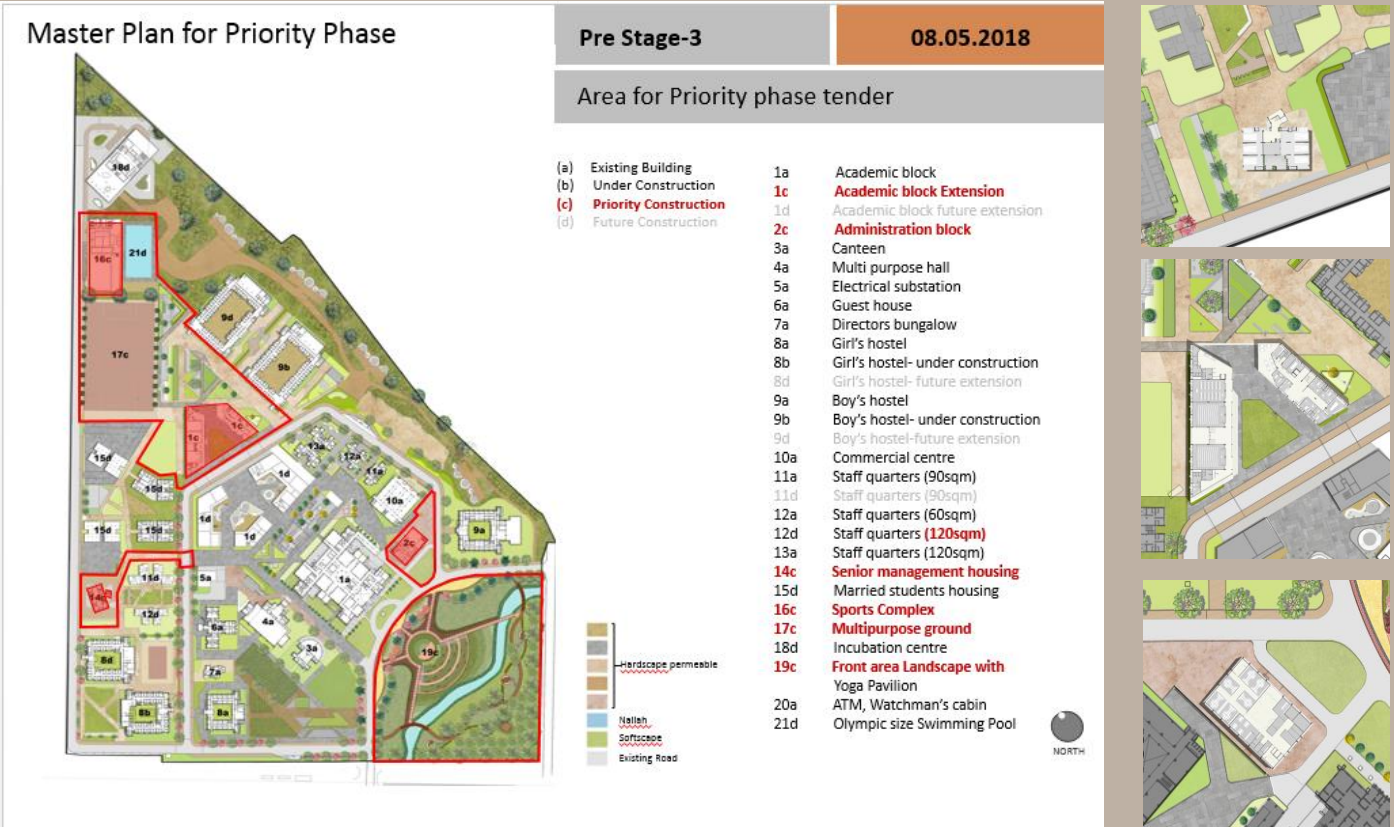

**Dr. S.P. MUKHERJEE INTERNATIONAL INSTITUTE OF INFORMATION TECHNOLOGY NAYA RAIPUR - 492002**

Ref:-IIIT-NR/Admin/2<sup>nd</sup> phase/2016/23      Date:-16/02/2018

To,  
The Executive Engineer (Civil)-III  
Naya Raipur Development Authority  
Raipur (C.G.)

Dear Sir,

Sub: - Approval of Illustrative Master Plan of IIIT-NR

Ref: - (a) Your letter No.504/4(3)/E-in-C/EE(C)-III/IIIT (Phase-I)/NRDA/2017-18 Raipur dated 15/02/2018

1. Kind attention is drawn towards the Illustrative Master plan of IIIT-NR submitted vide your above referred letter.

2. The Competent authority IIIT-NR has accorded approval for the illustrative Master plan of IIIT-NR. The copy of approved Master Plan is attached along with this letter.

3. Further, the following prioritized items detail plan and estimate may be prepared and submitted for approval of Competent authority. The priority may be read from (a) to (f).

a) Academic Building  
b) Administrative Building  
c) Services related Infrastructure  
d) Sports Complex  
e) Landscaping in front of Academic Block  
f) Higher management Quarters

**Encl:-** Approved Master Plan

*(Signature)*  
Estate officer

Copy to:-  
1) Shri Deepak Choudhary, Manager (PE&M), NTPC  
2) M/s RJB Consultant

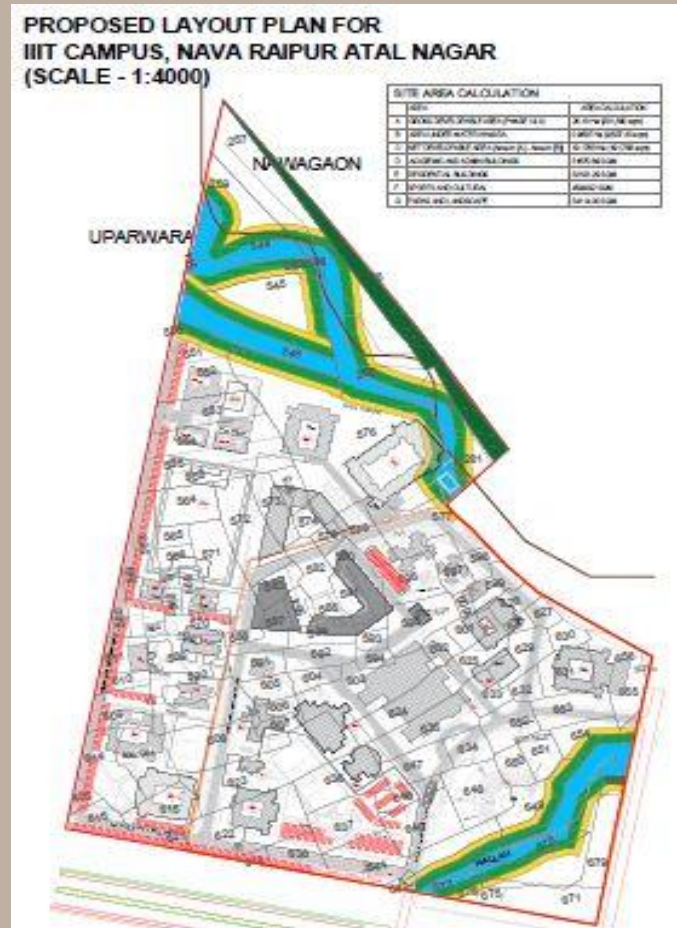

**Project: Land Survey , Land Assessment Study & Housing Master Plan For Katni Industrial Township**

Client: calderys India Refractories Ltd.

Location: Katni

Duration: 1st Aug 2016

Position: Founder and Chief Architect Planner

**Project Detail:** Major role in the project is as follows-

- Survey
- Land Assessment.
- Optional Land Parcel Master Plan
- Housing Master Plan

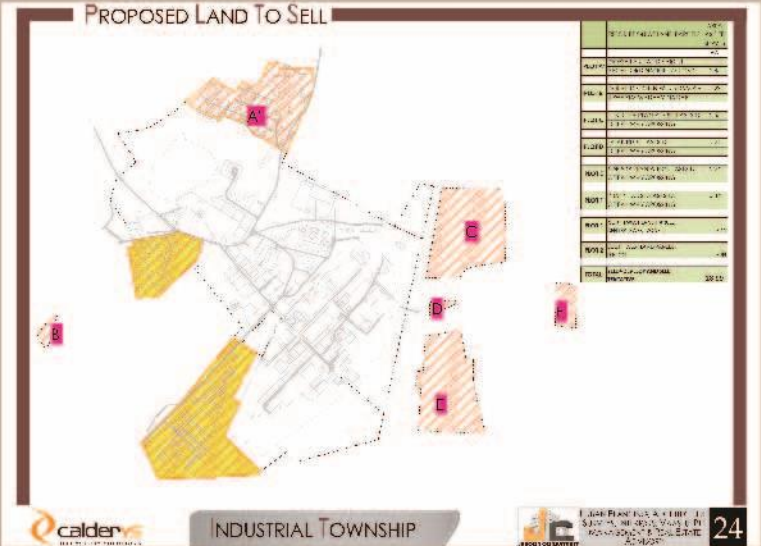
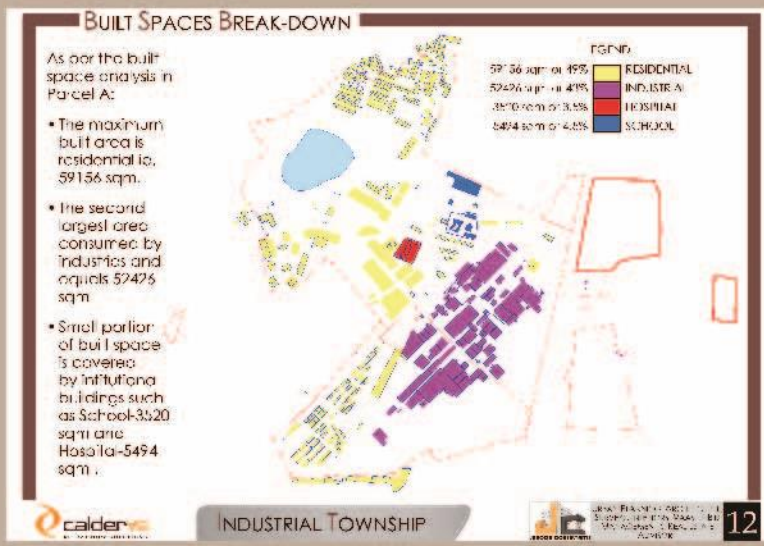
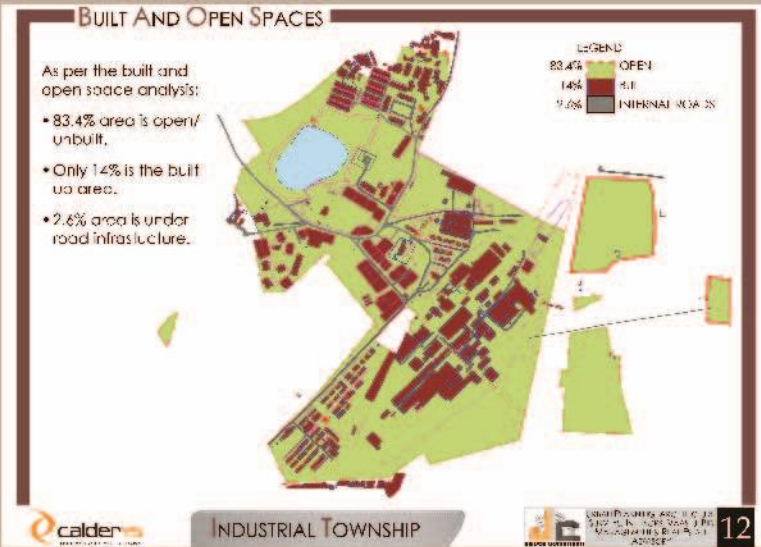
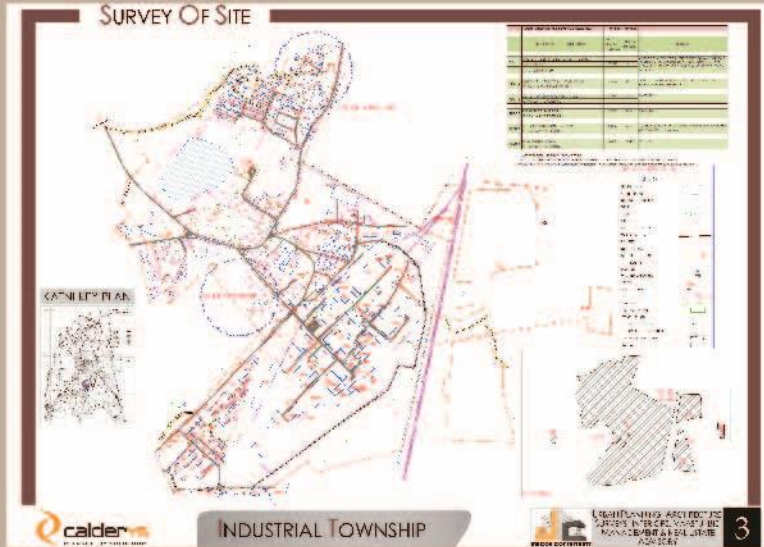

On 01-Aug-2016, at 6:32 PM, Sikander Yadav <[Sikander.Yadav@calderys.com](mailto:Sikander.Yadav@calderys.com)> wrote:

Dear Mustafa

Hope you reached safely to Katni. As discussed we would like to pen down our requirements so that during your assessment you can keep this things in mind

1. Complete overview of the township land parcels
2. Your assessment on different modes of best use with clear mapping of plan of the township in terms of outright sale of land parcels or sales by development or Sales by pieces or sales as per your best option for highest realisations.
3. Reorganization of the of staff quarters for optimal land area.
4. Proper accommodation for workers /staff at all times be kept in mind while preparing your options.
5. Your recommendations should always be cost optimal

Best regards

**Sikander Yadav**  
Chief Financial Officer

Tel : +91 712 256 3317 - Mob : +917507774420  
E-mail : [sikander.yadav@calderys.com](mailto:sikander.yadav@calderys.com)  
Calderys India Refractories Limited, Fidivi Tower 6th floor, Opp. Saraf Chambers, Mount Road, Sadar, Nagpur 440 001 India  
[www.calderys.com](http://www.calderys.com)  
<mime-attachment.gif>

From: Sikander Yadav/Calderys/IMERY3  
To: [mustafa7@owaf.com](mailto:mustafa7@owaf.com), [jaboonoon@owaf.com](mailto:jaboonoon@owaf.com)

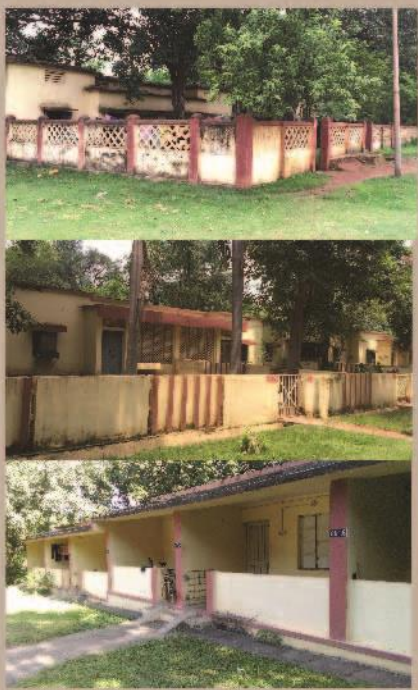

**Work Order By Mail**

**Project:** Planning Strategy for World Heritage Precinct of Old Puebla Town, Mexico  
**Sponsor:** French Government  
**Location:** Puebla, Mexico  
**Duration:** May-June, 2013  
**Themes of workshop:**

**Themes of Study:**  
 1- How to block the metropolis' shattered development?  
 How to find a new urbanity, create bonds with quality public areas?  
 How to avoid the urban sprawl? What density? How to involve the public transport  
 2- The city center  
 What are the repercussions of the city center's regeneration for the metropolis?  
 3- Housing  
 What housing forms can we create to answer the middle class and underprivileged population's demands regarding security, access to public services and quality of life? of farming land and promote the city's nearby landscape?  
 4- What governance?

Given the lack of dialogue between the 3 institutions: federal /city/state  
 What planning tools can we use for the metropolis?  
 What land management tool can we install?  
 Can we think about private-public partnerships?  
**Project:** International Workshop for sustainable Architecture at Reunion Island- selected from CEPT to represent India in the workshop which was represented by students of 31 countries in Asia

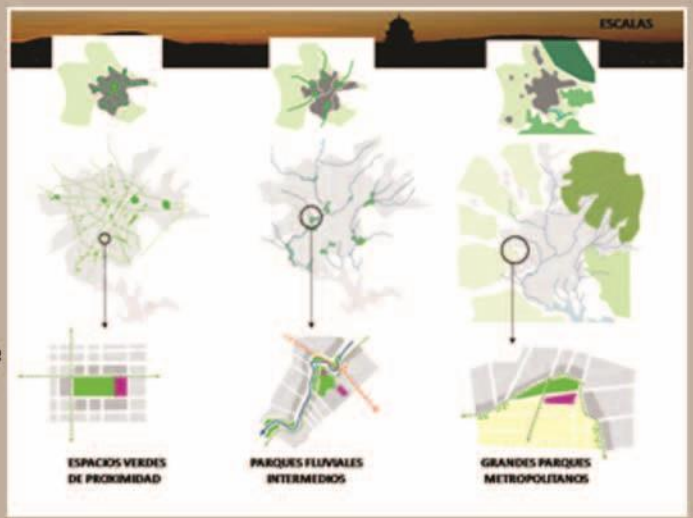



**Project:** Basic Research on the Development of Model Economic Township in Haryana State

**Client:** Nikken Sekkei Civil Engineering Ltd. , Japan

**Location:** Jhajjar District , Haryana State

**Duration:** September 2012 – Feb 2016

**Position:** Founder & Chief Architect Planner , JABCON Consultants,Raipur

**Project Detail:** Major role in the project is as follows-

- Topographical survey & GIS Analysis of the planning area.
- Techno Economic Feasibility For Investment of Japanese Developer & Mizuho Bank Japan.
- Master Planning for Industrial Planning.

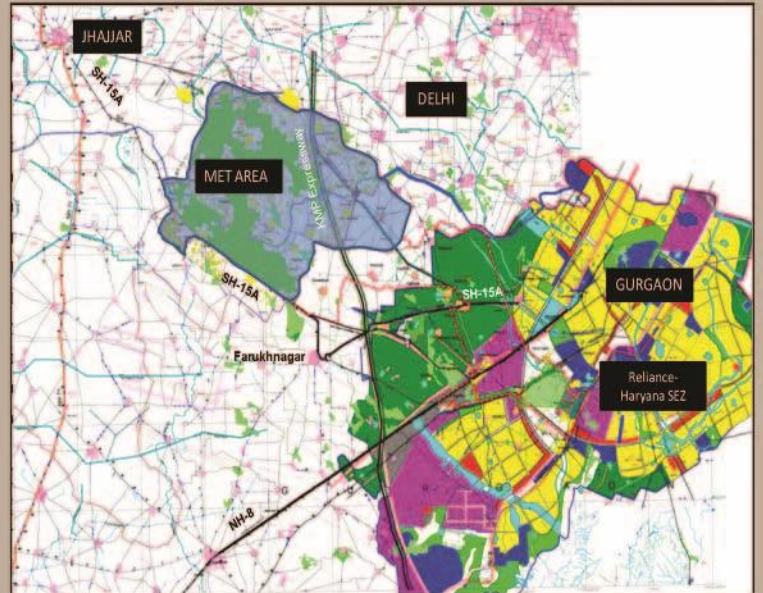
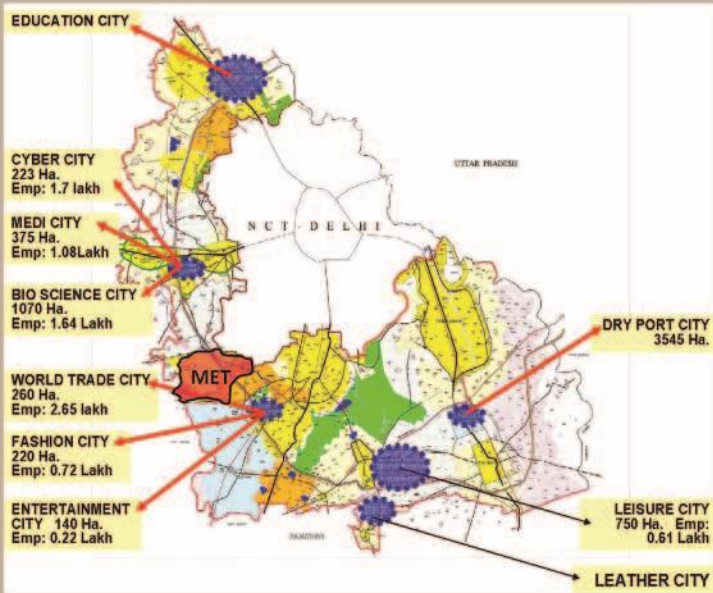

# SUB-CONSULTANCY SERVICE CONTRACT

No:01/NSC-JABCON/MET

New Delhi, 08 Sep., 2012

Re.: Basic research on the development of Model Economic Township in Haryana State

Today 8<sup>th</sup> September, 2012, we, including

## 1. Consultant

Name: Nikken Sekkei Civil Engineering Ltd

Representative: Minoru SAJI

Position: Project Manager

Address: 4-6-2 Koraihashi, Chuo-ku, Osaka-city, Osaka 541-8528, Japan

Tel: +81 6 6229 6399

Fax: +81 6 6229 3381

## 2. Sub-Consultant

Name: JABCON Consultants

Representative: Mustufa Ahmed

Position: Founder & Chief Architect Planner

Address: C/O JABCON Consultants, Office no 318, 3<sup>rd</sup> Floor, Progressive Point Building, Dhamtari Road, Raipur, 492001

Tel: +8120022552

Fax: + NA

**WHEREAS** Consultant has entered into a consultancy contract (hereinafter called "Main Contract") with Mizuho Bank, Ltd. and Murubeni Corporation (hereinafter called "Clients") to provide consultancy services in connection with the following project:

Basic research on the development of Model Economic Township in Haryana State (hereinafter called "Project")

**WHEREAS** Consultant has requested Sub-Consultant to provide certain parts of services of Main Contract;

**WHEREAS** Sub-Consultant is willing to provide Consultant with services for the above project

**NOW THEREFORE**, the two parties agree to execute this sub-consultancy services contract on the Project (hereinafter called "Contract") with the following terms and conditions:

Consultant hereby agrees to engage the Sub-Consultant and the Sub-Consultant agrees to perform the sub-consultancy services on the terms and conditions as described in this Contract and Appendices annexed hereto which constitute a part hereof, namely:

(a) Sub-Consultancy Service Contract;

*M. Saifi*

1/

  
**JABCON CONSULTANTS**  
Proprietor

(b) Conditions of Contract;

(c) Appendices consisting of:

Appendix A: Scope of Services

Appendix B: Deliverables

Appendix C: Implementation Schedule

Appendix D: Remuneration and Payment Method

**IN WITNESS WHEREOF**, this Contract has been executed by the parties' duly authorized representatives as of the date and year first above written.

For and on behalf of  
**Nikken Sekkei Civil Engineering Ltd**

Minoru SAJI – Project Manager

For and on behalf of  
**JABCON Consultants**

  
**JABCON CONSULTANTS**  
**Proprietor**

Mustufa Ahmed – Founder & Chief Architect  
Planner



## नए शहर में भी हो रायपुर की खुशबू

**राजधानी की लाइफ से विदेशी प्रभावित**

जर्मनी के राजधानी बर्लिन और लंदन के राजधानी के बीच के अंतराष्ट्रीय के रास्ते में स्थित एक नया शहर रायपुर अपनी खास पहचान के साथ ही देश के विकास के लिए एक नए रूप में उभरे हुए है।

रायपुर को पश्चिम में बंगाल की खाड़ी के तटवर्ती क्षेत्रों से जोड़ने के लिए एक नया रास्ता बनाया जा रहा है। यह रास्ता रायपुर को देश के बाकी हिस्सों से जोड़ेगा।

रायपुर में एक नया शहर बन रहा है। यह शहर नया रायपुर के नाम से जाना जाएगा। यह शहर रायपुर के विकास के लिए एक नए रूप में उभरे हुए है।

रायपुर में एक नया शहर बन रहा है। यह शहर नया रायपुर के नाम से जाना जाएगा। यह शहर रायपुर के विकास के लिए एक नए रूप में उभरे हुए है।

### REGIONAL SCALE - Transition

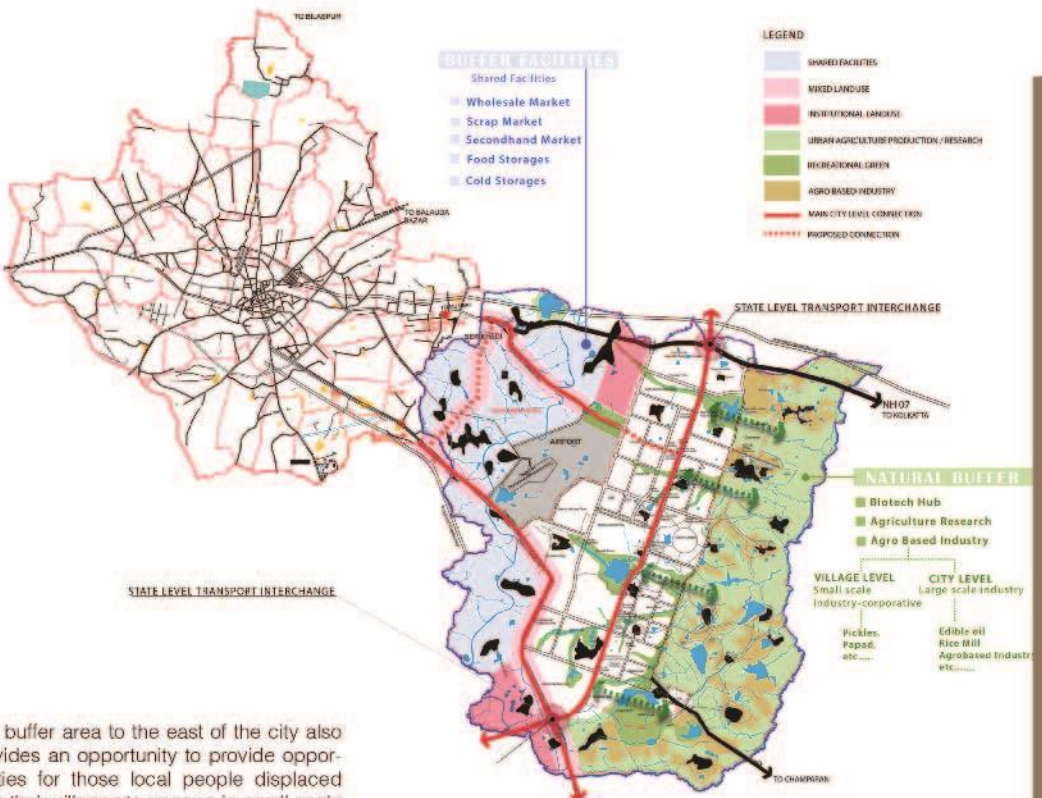
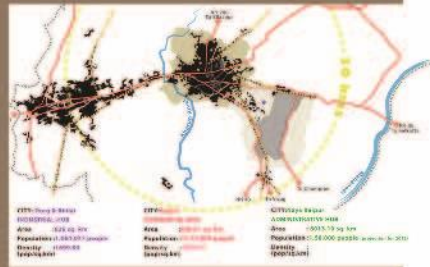

### Buffer area planning

The relationship between Raipur and Naya Raipur, and the buffer zone between, needs to be explored in more detail as it performs an important role as the transition zone between the two cities. This relationship needs to be defined as it will serve to establish the identity of Naya Raipur.

Decisions have to be made about the role of this land between whether it serves to separate or link the two cities. There are potentially two opposing forces at work whereby the two cities could either push against each other or alternatively connect and form a symbiotic relationship.

It is better to consider this land as forming a link between the two cities that could be used as an area where services could be developed that will serve both cities. This creates an opportunity to provide facilities such as wholesale markets, service industries, a truck terminal, cold storage, scrap market and food storage. This will allow for a stronger link between the two cities.

The buffer area to the east of the city also provides an opportunity to provide opportunities for those local people displaced from their villages to engage in small scale farming and horticulture. This approach will allow those villagers displaced from their original lands to be given the opportunity to engage in farming activities.

This approach also helps to resolve the question of the purpose of this land and its connection to Naya Raipur.



### आम नागरिकों के हिसाब से हो प्लानिंग

आम नागरिकों के हिसाब से हो प्लानिंग... (Text in Hindi discussing urban planning from a citizen's perspective).

### LAYOUT PLAN OF SECTOR 30



**Project:** Residential layout plan for Sector 30 In Naya Raipur  
**Client:** Naya Raipur Development Authority  
**Location:** Naya Raipur, Chhattisgarh  
**Duration:** May 2011– July 2011  
**Position:** Urban Planner

Project aims to plan a residential sector with existing nala and landscape to be allotted to private developers for residential development. The main challenge of the design was to achieve a reasonable density after living around 30% of space in open due to the existing Nala palm the layout in consideration to Transit oriented development principle keeping in mind that the BRTS system has been planned along one side of the road.



**Project:** Business plan for Vishakhapatnam Port Trust (Sep 2006- Jan 2007)  
**Client:** Vishakhapatnam Port trust  
**Location:** Vishakhapatnam & Mumbai  
**Duration:** September 2006 – January 2007  
**Position:** Land use Planner

**Description of Project:**  
 Visakhapatnam Port is a natural harbour, deep draft port on the east coast of India. Port of Visakhapatnam is considered as the gateway to the east coast of India. It plays a crucial role as the middle point distribution base for Southern, Eastern, Central and Northern states of India. It is well appreciated of all Indian major ports for its outstanding performance and productivity.

Visakhapatnam Port Trust has undertaken this study to Prepare a business plan for the Port that is in line with its competitive advantages and capabilities and can be implemented without government financial support The scope of the study includes: Defining a long term vision for the Visakhapatnam Port Trust, Establishing goals to be achieved over the next seven years ,Identifying the strategy to be followed to reach these goals ,Recommending a detailed plan of action to implement the strategy and Identifying sources of financing for all proposed investments. Land use section is an important part of this study.

TCS has tied up with Rotterdam Maritime group of Holland for this project. Land use section of the study demanded to study the existing land use profile and scope of development within the existing Land use and give a Preliminary Land use plan considering the future business of the port.

**Responsibilities:**  
 Technical Assistance to Project Team, specific responsibility are as follows

- Responsible for client coordination, interaction with consultants and agencies.
- Existing Land use assessment
- Preparation of Land use proposal and making presentation to clients.
- Pre feasibility study for he proposed projects



**Project:** Residential sector plan for CM, GOVERNOR AND ALL MINISTERS & sector 18 of Naya Raipur  
**Client:** Naya Raipur Development Authority  
**Location:** Naya Raipur, Chhattisgarh  
**Duration:** Feb 2012 – March 2012

**Position:** Urban Planner

**Description of Project:** The project aims to plan residential facilities for state dignitaries like CM, Governor and all ministers with adequate facilities. The highlight of the design is the use of the existing water body as an focal point of design for recreation and relaxation

**Project:** Residential Township at Sunita Park near Magneto Mall, Raipur

**Client:** Mr. Abhikhek Gupta

**Duration:** 2011-2012

**Location:** Raipur

**Position:** Founder and Chief Architect Planner

**Project Detail:** Major role in the project is as follows-

- Master Planning of 40 acre township.
- Review of local GDCR
- Submission of Layout in Town and Country Planning.
- Architectural Planning
- Infrastructure Design

### Concept

- Self Financing business model
- Multi Phasing for shorter investment and higher returns
- Sustainable Planning
- Bicycle Friendly Planning
- Barrier Free Planning
- Green Parks – Central Park
- Shopping and Entertainment
- Integrating old and new development
- Maximum Utilization of FAR and Maximum Profits
- High Tech infrastructure and Amenities
- Luxurious Apartments



1. Banglow (Attached)  
Plot Area = 240.49 Sq. M  
B/U Area = 337.26 Sq. M  
FSI = 1.4

1. Banglow (Independent)  
Plot Area = 306.69 Sq. M  
B/U Area = 429.36 Sq. M  
FSI = 1.4

- 3 M open space from 3-side
- 4.5 M front open space
- 81 Attached Banglows
- 30 Independent Banglows

**Banglows**

**High Rise and Mid Rise Apartments**

- 1/6 Commercial FSI
- Clustered patio pattern housing

**Apartments**

**Offices, Mall, and Hotels**

- High Rise Office
- Mid Rise Offices
- Open Space System

**Commercial**

**Project:** Preparing the Inclusive Tourism Infrastructure Development Project

**Client:** Asian Development Bank

**Location:** Mumbai, Delhi, Himachal Pradesh, Uttarakhand, Punjab, Sikkim, Tamil Nadu,

**Duration:** Aug 2008 – September 2009

**Position:** Tourism Infrastructure

**Description of Project:**

The project is dedicated to finalize the state-level tourism road maps based on the national tourism infrastructure study conducted in 2007 and reconfirm or identify the priority tourism circuits, identify the priority subprojects within those circuits to be included in the ensuing ADB-funded loan project, review and assess the feasibility of subprojects based on technical, institutional, environmental, social, economic, financial, and other relevant factors, prepare proposals for project implementation arrangements, and identify project costs and a financing plan, as well as the project assistance modality, (vi) prepare all the safeguard documents, and all other details required for an ADB loan project. Responsibilities:

The scope of work includes tourism infrastructure assessments, coordination of site investigations and surveys, preparation of designs and cost estimates and implementation arrangements of the subprojects to be included in ADB funded loan project in each state.

- Review the report of India Tourism Infrastructure Study, compile or new and updated government and State plans, and other data and information, and reports; undertake field trips and meet with state officials to discuss the state tourism infrastructure requirements.
- Assist the team and tourism planners in the identification of state tourism infrastructure Requirements and the priority circuits (to be reflected in each state road map).
- In consultation with national and international tourism planners and team leader, identify high priority tourism infrastructure improvements in the priority tourism circuits.

**ASIAN DEVELOPMENT BANK  
FAX-BACK REPLY FORM**

ADDRESSEE: Cristina C. Meimban  
Senior Operations Officer  
Central Operations Services Division 1

DESTINATION FAX: +63(2) 636-2470  
+63(2) 636-2471

DATE: PAGE ONE OF:

**CONFIRMATION OF ACCEPTANCE**

Contract	S15959
Project	TA - 7014 (IND) : Preparing the Inclusive Tourism Infrastructure Development Project
Expertise	Tourism Infrastructure Architect
Source	Local
Category	Firm

(Please mark the relevant boxes and sign your confirmation over the corresponding name)

We have carefully read your offer letter dated 07 August 2008 and all its attachments. I accept the offer on behalf of TATA Consultancy Services Limited. Indicated below is our firm's payment remittance information.

- I will confirm after you respond to my inquiries below or in my letter attached.
- Thank you for your offer, but we cannot commit Mustufa Jameel Ahmed this time.

  
D. Jagannadha Rao  
Senior Consultant

7 Aug 2008  
Date

I affirm my personal obligation to comply with the covenants concerning my services as specified in the Terms and Conditions and the Terms of Reference.

  
Mustufa Jameel Ahmed  
Consultant

7 Aug 2008  
Date

Remarks:

**Payment Remittance Information**

For USD	For Other Currencies
Bank Name: BANK OF AMERICA NA Address: EXPRESS TOWERS, MARINA POINT MUMBAI - 400001, INDIA SWIFT CODE: BOFAIN33 Payee: Tata Consultancy Services Limited Account No.: 72 017026	Bank Name: Address: Payee: Account No.:

NOTE: Instead of fax, you may also scan this page and e-mail to cos1@adb.org.

### ADB to invest \$ 90-m in tourism

**Team meets CM; partnership on, says Dhumal**

**BJP seeks Rs 1,598-cr package for state**



The ARAB Development Bank (ADB) is set to invest over \$ 90 million in tourism-related infrastructure in Himachal Pradesh.

Chief Minister Shree Harsimrat Kaur Badola met ADB officials in Chandigarh, Punjab, on August 6, 2008, to discuss the state's tourism infrastructure development plan.

The CM said that the state is seeking a loan of \$ 90 million from ADB to develop tourism infrastructure in the state. She said that the state is also seeking a loan of \$ 1,598 crore from the Government of India to develop tourism infrastructure in the state.

The ADB will use the loan to develop tourism infrastructure in the state. The ADB will also use the loan to develop tourism infrastructure in the state.

The ADB will use the loan to develop tourism infrastructure in the state. The ADB will also use the loan to develop tourism infrastructure in the state.

### TA 7014



**INDIA SUSTAINABLE AND INCLUSIVE TOURISM INFRASTRUCTURE DEVELOPMENT PROJECT**

In the States of Himachal Pradesh, Punjab, Tamil Nadu and Uttarakhand

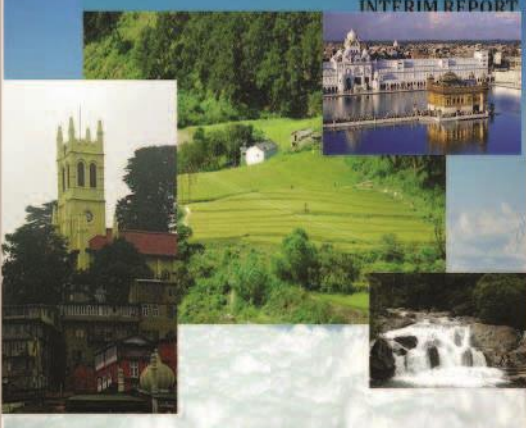
#### INTERIM REPORT



25 November 2008



S15959 AHMED 08-12-2008



Asian Development Bank

## Certification

12 August 2008

**Contract No. S15959**  
**TA - 7014 (IND) : Preparing the Inclusive Tourism Infrastructure Development Project**

To whom it may concern:

This is to confirm that Mr. Mustufa Jameel Ahmed (the Consultant) has been retained by TATA Consultancy Services Limited as an expert to provide consulting services under the captioned technical assistance (TA) project to Asian Development Bank (ADB).

Accordingly, in terms of Article II, Section 2.02(b) and Sections 7 to 9 of the Schedule to the TA Framework Agreement dated 10 July 1996 between the Government of India and ADB, the Consultant shall be entitled to the privileges and immunities as detailed therein. The Consultant shall not be exempt from, and shall bear the cost of any taxes, duties, fees, or other impositions levied under the laws and regulations in effect in the territories of India in respect of any payments made to the Consultant in connection with the carrying out of the captioned TA project.

*[Signed 04 Aug 2008]*

Robert Rothery

**For Director**

Central Operations Services 1



S15959 AHMED 08-12-2008



Asian Development Bank

**FAX**

South Asia Department  
Urban Development Division, SARD  
6 ADB Avenue, Mandaluyong City  
1550 Metro Manila, Philippines  
Tel +63 2 632 4444  
Fax +63 2 636 2293

Page 1 of 1

To: D. Jagannadha Rao Mumbai, Maharashtra, IND	Date: 12 August 2008 Fax: +91 022 6778 9000
Originator: <sup>for</sup> Gulfer Cezayirli <i>Boenawan's</i>	Approved by: Hun Kim <i>[Signature]</i> Director, SAUD

**NOTICE TO PROCEED**

Dear Mr./Ms. D. Jagannadha Rao:

**Contract No. S15959**

**TA-7014 (IND): Preparing the Inclusive Tourism Infrastructure Development Project**

This serves as notice to proceed with the Services as per Definitions Section 4 and Specific Conditions Section 1 of the Contract. Please advise Mr. Mustufa Jameel Ahmed to commence the Services on Monday, 11 August 2008 and report to the undersigned, (E-mail: gcezayirli@adb.org) at the assignment location. The services shall be completed by Thursday, 08 January 2009. Please note if the commencement date and completion date indicated above are different from Specific Conditions Section 1, the dates indicated above shall prevail.

Request for Payment forms are available via download from <http://www.adb.org/Consulting>

Sincerely,

*Boenawan's*

<sup>for</sup> **Gulfer Cezayirli**  
Principal Urban Development Specialist  
Designated by Director  
Urban Development Division, SARD

**Project:** Consultancy services for Carrying Out the Primary Surveys for 'Planning for Rural Public Transport (PRPT), Bilaspur District (Package A)

**Location:** Bilaspur District

**Duration:** Aug 2015-Feb 2016



UMTC/PRPT/RJD/BLSPR/02

19<sup>th</sup> August, 2015

**M/s. JABCON Consultants, Raipur**

Office no 318, 3rd Floor, Progressive point,

New Dhamtari road, Raipur, Chhattisgarh,

INDIA. Ph. No. +91 – 812-0022552

Email: - jabconconsultants@gmail.com

**Subject: Consultancy Services for carrying out the Primary Surveys for 'Planning for Rural Public Transport (PRPT)', Bilaspur District (Package A).**

Dear Sir / Madam,

This has reference to your proposal vide letter / e-mail dated 3<sup>rd</sup> August 2015, for undertaking the subject assignment.

UMTC has undertaken a research study under "Special Project Head" with the support from Ministry of Rural Development, Government of India and National Rural Roads Development Agency (NRRDA) to understand the transport needs of the rural population and design a sustainable rural public transport services. Bilaspur district in the state of Chhattisgarh has been taken as a pilot district to study and roll out the initiative and subsequently planning to roll out to the entire state and other states in India.

We are pleased to inform you that your proposal has been accepted and we hereby authorize JABCON Consultants for providing consultancy services immediately for carrying out the Primary Surveys for 'Planning for Rural Public Transport (PRPT)', Bilaspur District (**Package A**) on terms and conditions as detailed in the enclosed Annexure-A to this Work Order.

This Work Order is being issued to you in duplicate. Kindly return the duplicate copy of the same, duly signed by you on all the pages of this Work Order, as a token of your acceptance.

Yours sincerely,

For Urban Mass Transit Company Limited



DB Srinivas, Vice President (Technical)

Encl: As above

Received and Accepted  
For JABCON Consultants, Raipur



Mustafa Ahmed, Founder & Chief  
Architect Planner

# DESIGN BUILD SERVICES (END TO END EXECUTION)



**JABCON CONSULTANTS**

**Project:** A Mix Land Use Project At Key Location Of Raipur THE HAKIMI ARCADE Including Architect Den Penthouse Name Muffadal Sky Villa

**Client:** Hakimiddin Ali

**Location:** OCM Chowk, Raipur (C.G)

**Duration:** 2022 - 2024

**Position:** Chief Architect And Planner

**Project Detail :**

**Major Role In Project :** - Total Design Build services, Laisoning work & Real Estate consulting work

**Scope Of Work: -**

- Interior design services
- Architectural design services
- MEP designs
- Laisoning work
- Total end to end constructions



**Project:** Residence  
**Client:** Shri Deepak Jha  
**Duration:** 2022 - 2024

**Location:** Sector 30, Naya Raipur (C.G)  
**Position:** Chief Architect And Planner

**Project Detail :**

**Major Role In Project :** - Total Design Build services & Laisoning work

- Scope Of Work: -**
- Interior design services
  - Architectural design services
  - Laisoning work
  - Total end to end constructions

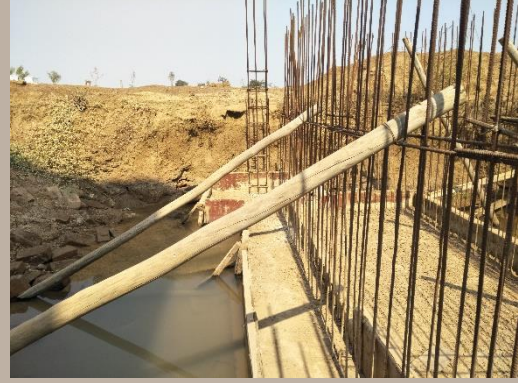

**Project:** Residence of Shri Bhushan Gokhalani Humming Courterie

**Client:** Bhushan Gokhlani

**Duration:** February 2021 - July 2022

**Location:** Raipur (C.G)

**Position:** Chief Architect And Planner

**Project Detail :**

**Major Role In Project :** - Total Design Build services end to end & Laisoning work

**Scope Of Work: -**

- Interior design services
- Architectural design services
- Financing services
- Laisoning work
- Total end to end constructions



**Project:** Ghiya Residence Total Interior And Civil Modification Execution

**Client:** Mustafa Ghiya

**Location:** Amanaka, Raipur (C.G)

**Duration:** February 2019

**Position:** Chief Architect And Planner

**Project Detail :**

**Major Role In Project :** - Total Design Build Services End To End

- Scope Of Work: -**
- Interior Design Execution Services
  - Total end to end constructions

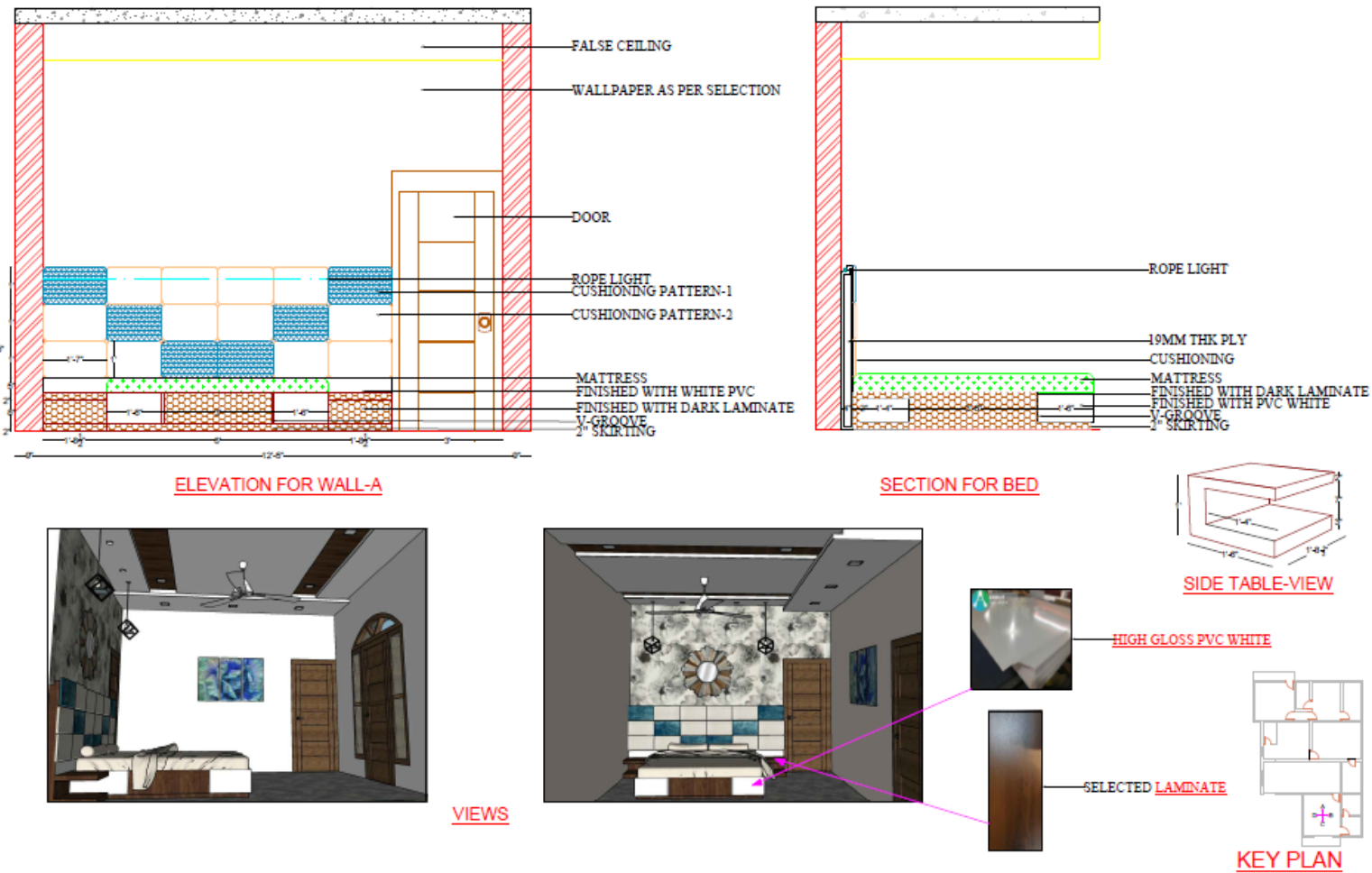

**PROPOSED INTERIOR LAYOUT FOR MASTER BEDROOM @ GHIYA RESIDENCE,RAIPUR (C.G.).**

**TITLE :-**  
DETAIL WORKING DRAWING.

**DATE:-**  
03 OCT 2019

**REVISION:-**  
02

**NORTH**

**DRAWN BY:-**  
TASNEEM AZIZ



**JABCON CONSULTANTS**  
URBAN PLANNING, ARCHITECTURE, INTERIORS,  
VAASTU & REAL ESTATE ADVISORY



**Project: Upgradation Additional & Interior Design With Total Design Build Services For Kapasi Residence**

**Client: Juzar Kapasi**

**Duration: 2018**

**Project Detail :**

**Major Role In Project :** - Total Design Build services including total interior design execution services end to end

**Location: Sadar bazaar, Raipur (C.G)**

**Position: Chief Architect And Planner**

**Scope Of Work: -**

- Interior design services
- Architectural design services
- Structural design services
- Total end to end constructions

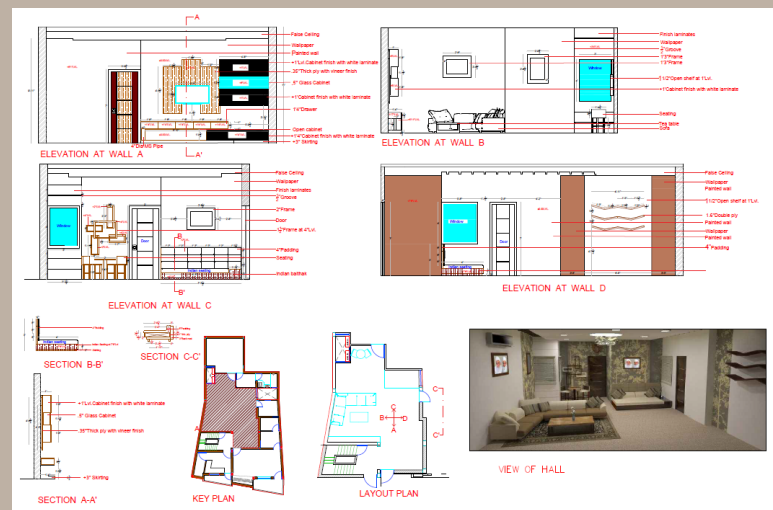
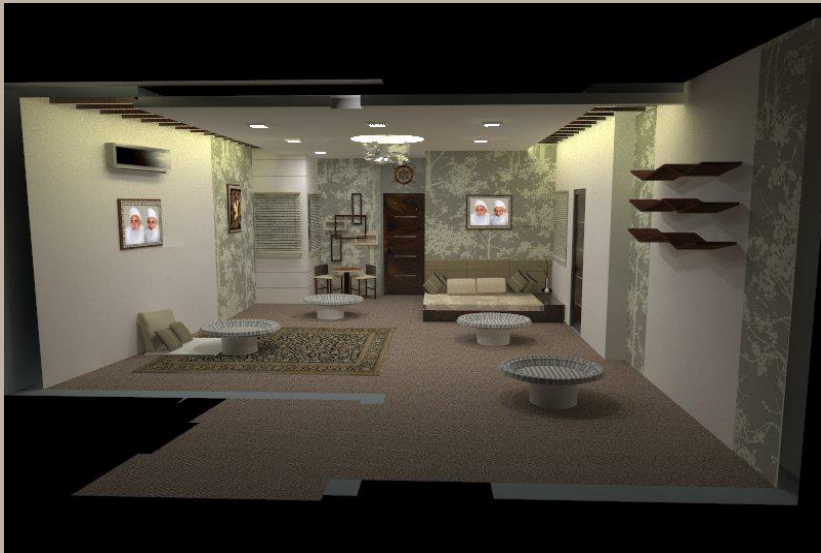



**Project:** Restoration, Renovation And Modification Of A Residence

**Client:** Rohit Jain

**Location:** Choubey colony Raipur (C.G)

**Duration:** 2016

**Position:** Chief Architect And Planner

**Project Detail :**

**Major Role In Project :** - Total Design Build services including total interior design execution services end to end

**Scope Of Work: -**

- Interior design services
- Architectural design services
- Structural design services
- Financing services
- Laisoning work
- Total end to end constructions



**Project:** Residence

**Client:** Shri Afzal Ahmed Khan

**Duration:** 2022

**Project Detail :**

**Major Role In Project :** - Total Design Build services including total interior design execution services end to end

**Location:** Tikrapara, Raipur (C.G)

**Position:** Chief Architect And Planner

**Scope Of Work: -**

- Interior design services
- Architectural design services
- Structural design services
- Laisoning work
- Total end to end constructions

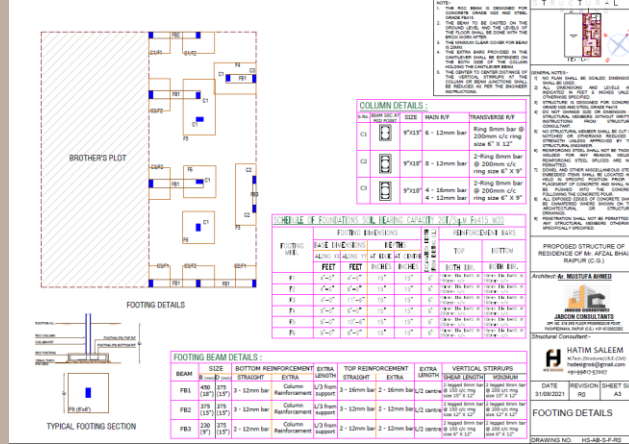

# LAISONING SERVICES FOR PRIVATE, GOVERNMENT & PSU CLIENTS



**JABCON CONSULTANTS**

**Project :** NH 200 – 300 Multispecialty Hospital Laisoning Work

**Client :** NH Ltd Bangalore

**Location:** Devpuri Raipur (C.G).

**Duration:** November'2023 – may' 2024

**Position:** Chief Architect and Planner

**Project Detail :**

**Scope Of Work :** NOC Approval Work, T & CP Layout Approval Work, Fire NOC work & Final Building Permission Work

**Major Role In Project :** Laisoning Consultant

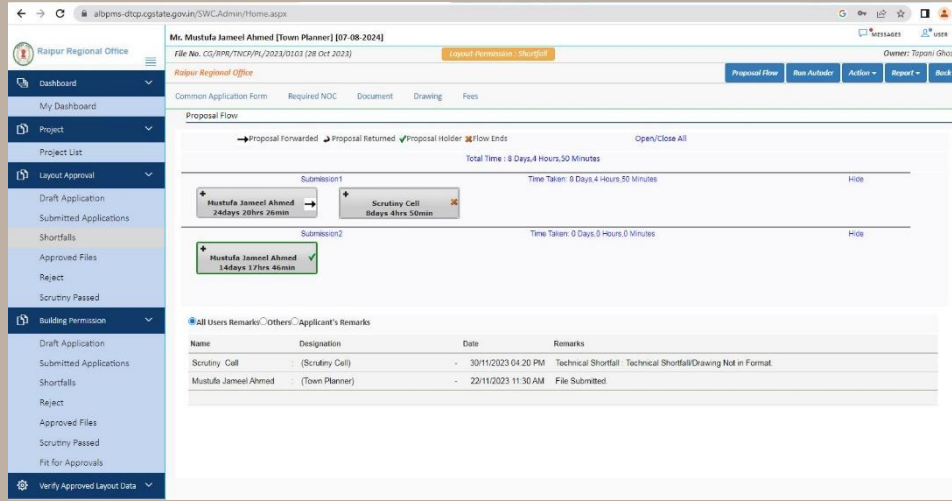

**Screenshot of online application process**

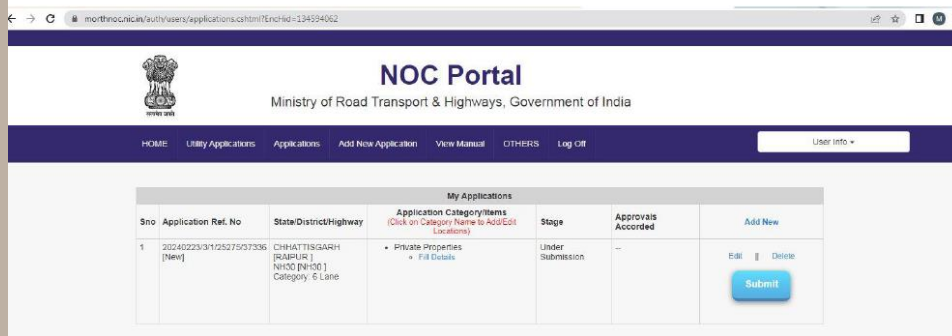

**Online MORT formal NOC receipt**

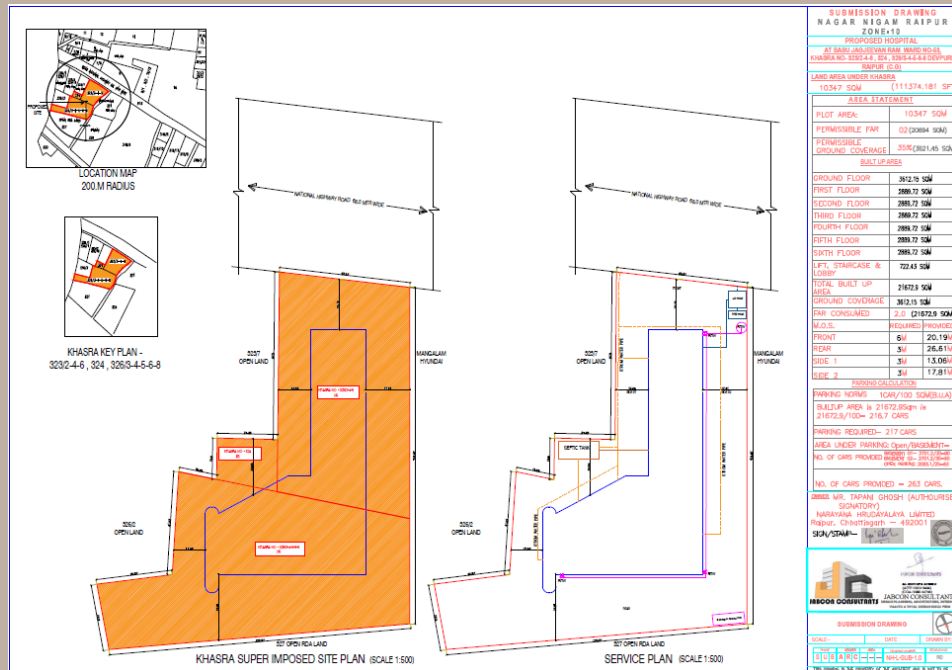

**Final T & CP layout approval drawing**

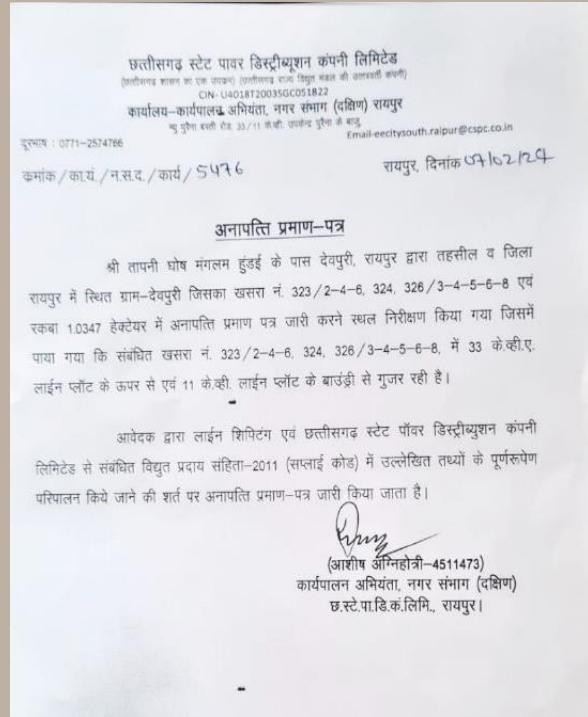

**CSEB NOC**

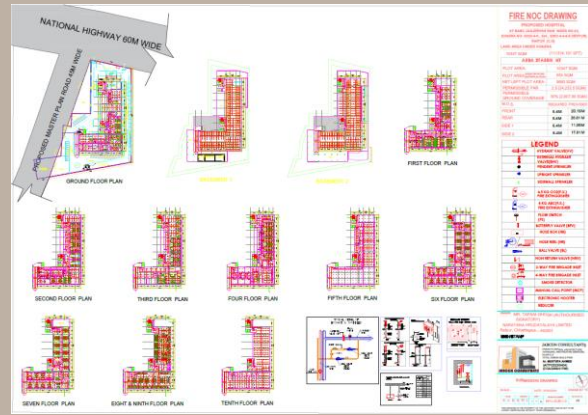

**Fire NOC application drawing**

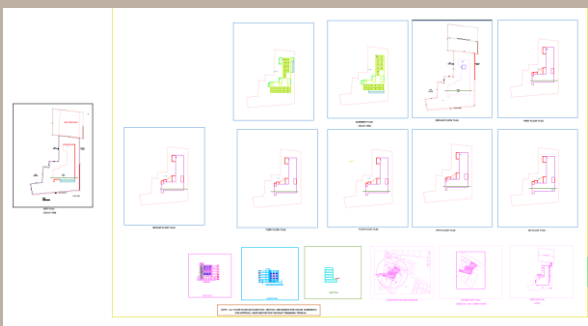

**Online DCR drawing**

**Project :** Laisoning Services For Maruti Suzuki Showroom

**Client :** Maruti Suzuki Pvt Ltd

**Location:** Sector 13 As Well Maruti Service Centre At Sector 5 Raipur, C.G.

**Position:** Chief Architect and Planner

**Duration:** 2019 - 2021

**Project Detail :**

**Scope Of Work :** All Statutory Approvals On Behalf Of Client

**Major Role In Project :** Laisoning Consultant

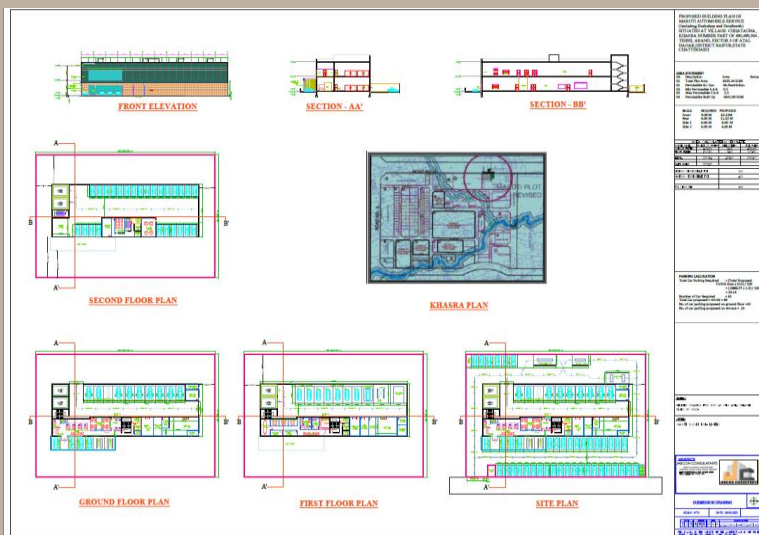
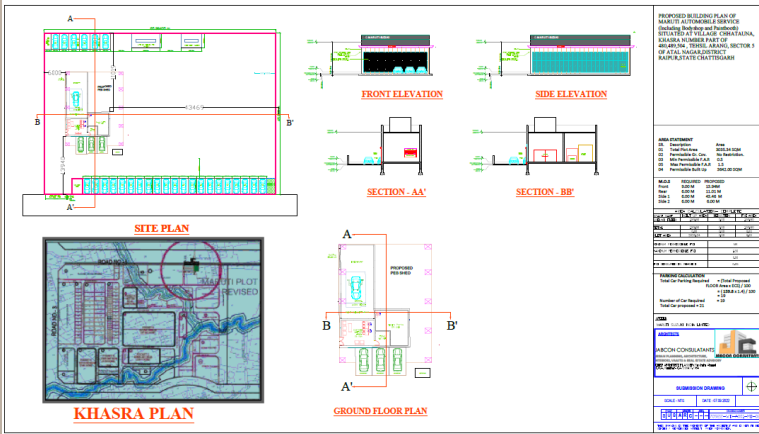

**Vendor Code Registration Form (CU4) (New Vendor / New Site)**

Sr No	Description	Details	Mandatory Documents required
<b>A Basic Details</b>			
i)	Name of Vendor/Service provider (As per Registration Certificate)	Mustafa Jameel Ahmed	Copy of Registration of Firm/Company etc
ii)	Existing Vendor Code, if any (Compulsory in case of modification)	-	-
iii)	Income tax Status (Individual/Firm/Company etc)	Individual	Copy of PAN Card
iv)	Address	318 Progressive Point, Lalpur, Raipur Ward no 51, Ravindranath Tagore Raipur	-
v)	Name of MD/CEO/CFO/Authorized person	Mustafa Jameel Ahmed	-
vi)	E-mail ID of MD/CEO/CFO/Authorized person	mustafa3@gmail.com	-
<b>B Other Details</b>			
i)	PAN Number	AHOPAB472B	Copy of PAN Card/Proprietorship Declaration form/No PAN Declaration
ii)	GST Registration Number	22AHOPAB472B2EM	Copy of GST Registration (GST-REG-06)
iii)	Registration Number (like for Companies, issued by Registrar of Companies)	2015000083/RPR/S/2015	Copy of Registration of Firm/Company etc
iv)	Micro, Small Medium (MSME) status (Yes/No)	No	If yes, Attach Certificate
<b>C Bank Details</b>			
i)	Bank A/C No	39144191435	EFT form with cancelled cheque <i>Not a Debit</i>
ii)	Bank Name	STATE BANK OF INDIA	-
iii)	Bank Branch, Code and Address with PIN Code	NEW RAJENDRA NAGAR (16156)	-
iv)	RTGS (Real Time Gross Settlement)/NEFT (National Electronic Fund Transfer)/IFSC CODE	SBIN0016156	-
v)	SWIFT Code	SBININ16156	-
<b>D Vendor type (Pl tick Appropriate)</b>			
		Currency, If Overseas	
<p><b>Declaration (By authorized signatory/CEO/CFO/MD of vendor/service provider)</b>          I hereby declare you that all the above information's are true &amp; correct to the best of my knowledge and belief.</p> <p>Name :- Mustafa Jameel Ahmed          Place :- Raipur          Designation :- Chief Architect Planner          Date:- 27.07.2020</p> <p style="text-align: right;">Signature with Seal          JAIKON CONSULTANTS</p>			
<b>MSIL DETAILS &amp; SIGN-</b>		<b>FOR INTERNAL USE:</b>	
		INITIATOR	DEPTT HEAD
NAME			DIV HEAD
SIGNATURE			
DEPTT/DIVISION			
INTERCOM/MOBILE NO			
DATE			
PLACE		Tentative date of closure of this vendor	

**NOTE-MSIL TEAM Please refer guidelines before submission of this form**

**Sector 5 Final Layout Plan & Final Building Permission Drawing**

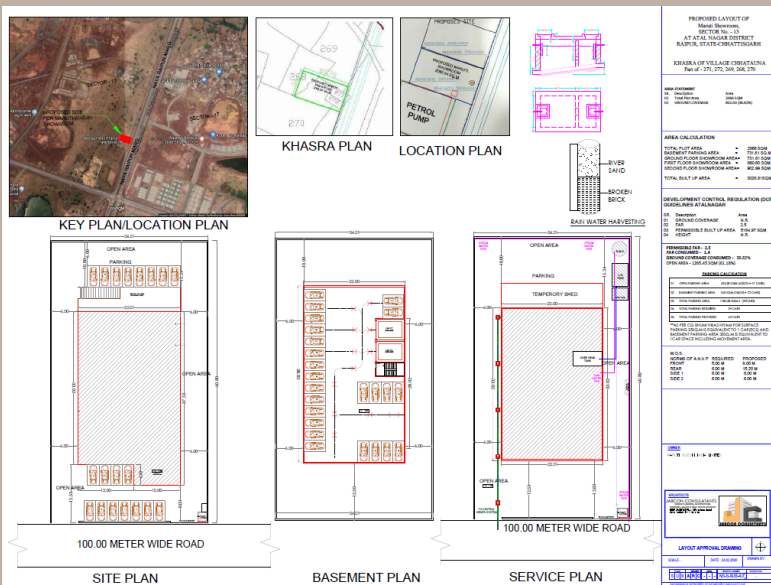
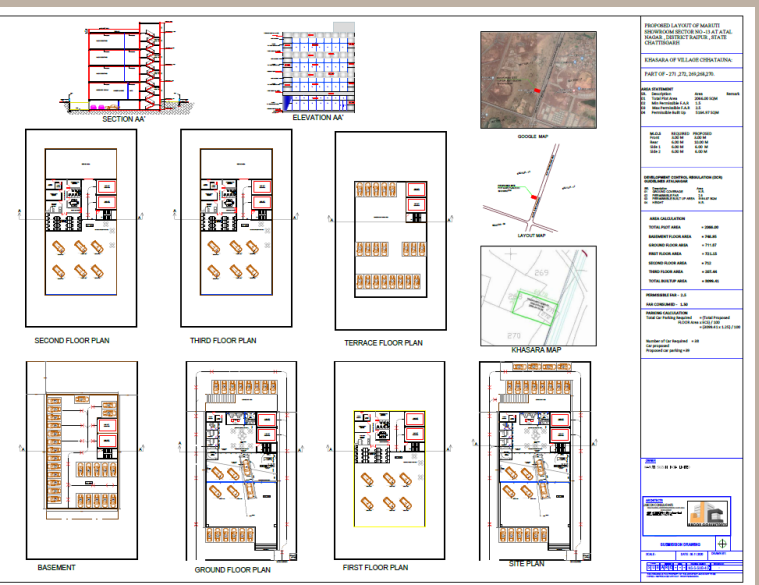

**Sector 13 Final Layout Plan & Final Building Permission Drawing**

# Project: Laisoning Services For RBI Office Building

Client: : RBI

Duration: 2017 - ongoing

Location: Naya Raipur (C.G)

Position: Local Architect

## Project Detail :

Scope Of Work : All statutory approval work

Major Role In Project : Local Architect

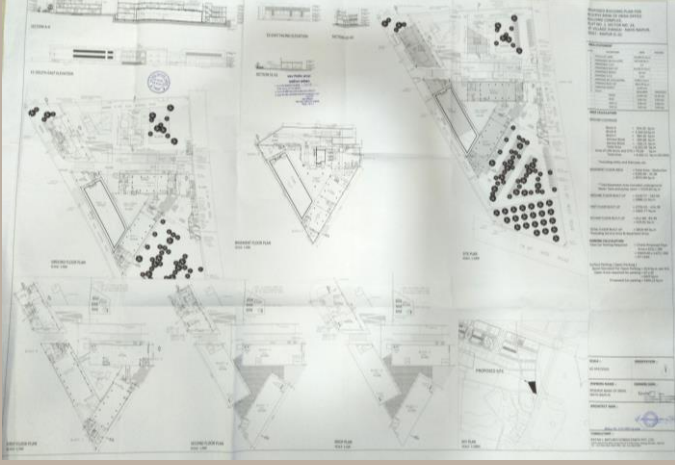

Approved Building Permission Drawing

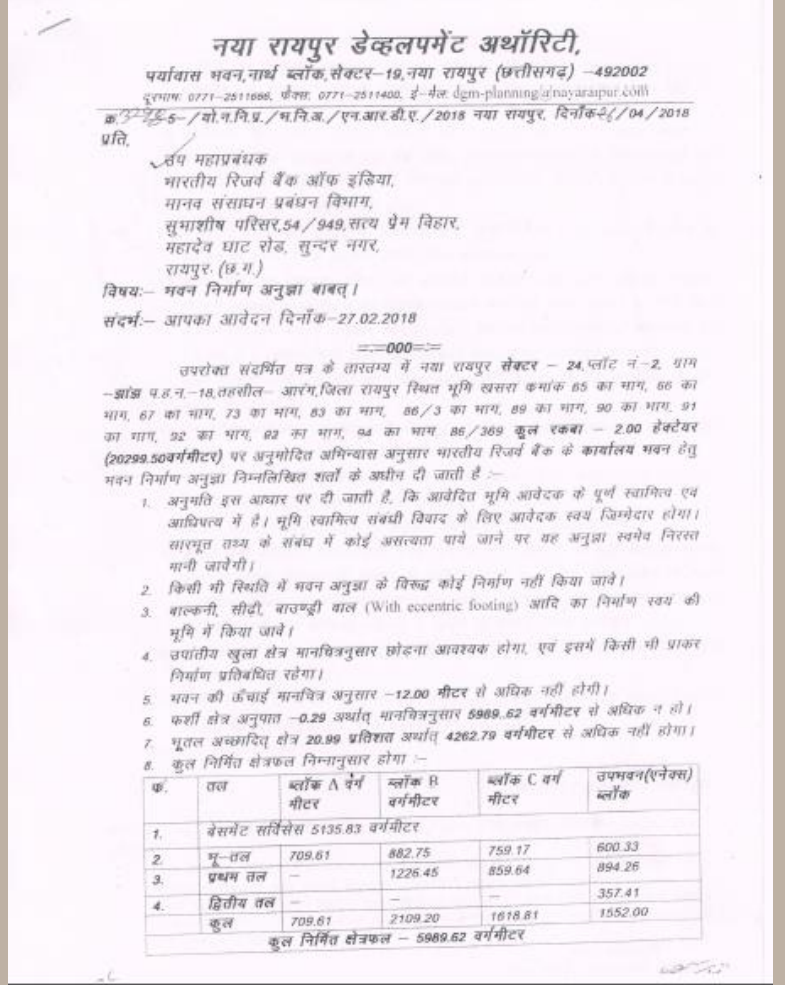

Final Building Permission Drawing



छत्तीसगढ़ अग्निशमन एवं आपातकालीन सेवाएं



होम



NOC के लिए आवेदन करें



पासवर्ड परिवर्तित करें

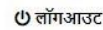

लॉगआउट

आवेदन पत्र प्रिंट करें

## आवेदन की वस्तुस्थिति

NOC जारी किया जा चुका है

Download NOC

SN	Action	Action Date	Action Done By	Remark
1	NOC Issued	05 Dec 2023	Mayank Shrivastava	NOC Issued
2	Inspected	05 Dec 2023	Pushpraj Singh	दिनांक 05/12/2023 को आवेदित संस्था से श्री अविनाश चौधरी की उपस्थिति में आवेदित परिसर का निरीक्षण किया गया। उक्त परिसर ( खाली प्लाट नंबर 02 सेक्टर 24 , नवा रायपुर ) राष्ट्रीय भवन निर्माण संहिता भाग 4 (2016) के ग्रुप - E , सब डिवीज़न E - 1 रेफ़रेंस 3.1.6 के अंतर्गत आता है। परिसर में निर्मित होने वाले भवन में उक्त मानक के अनुसार अग्नि सुरक्षा उपकरण / प्रणालियाँ स्थापित करने हेतु निरीक्षण के दौरान प्रस्तुत नक्शों में मानक को दर्शाया गया है। अतः भवन निर्माण होने पर उक्त उपकरणों को स्थापित करने की शर्त पर संस्था को भवन निर्माण पूर्व अग्नि सुरक्षा प्रमाण पत्र प्रदान करने की अनुशंसा की जाती है।
3	Inspection Team Assigned	14 Nov 2023	Mayank Shrivastava	Inspection team assigned
4	Application Submitted		Applicant	आवेदन किया गया

**Project: IIIT Project Laisoning Services**

**Client: : NRDA**

**Duration: 2017 - ongoing**

**Location: Naya Raipur (C.G)**

**Position: Consortium & Laisoning Architect**

**Project Detail :**

**Scope Of Work : All Laisoning Statutory Approval Works**

**Major Role In Project : Consortium & Laisoning Architect**

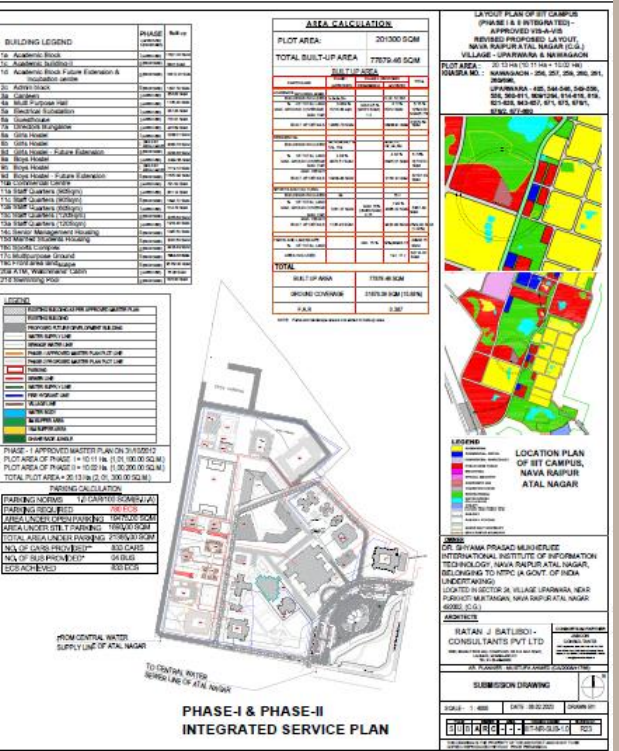
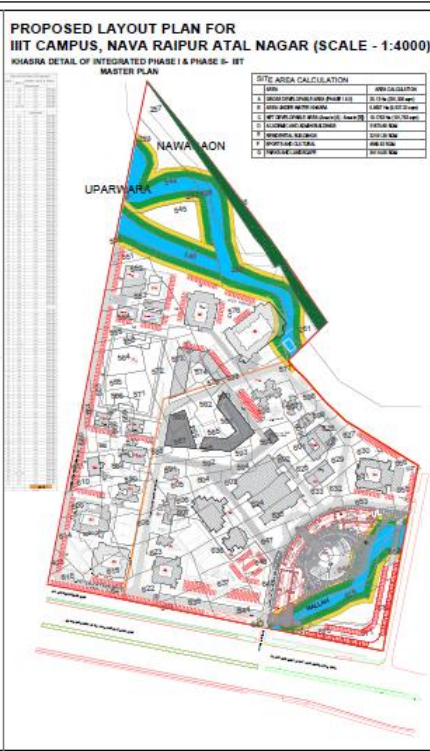
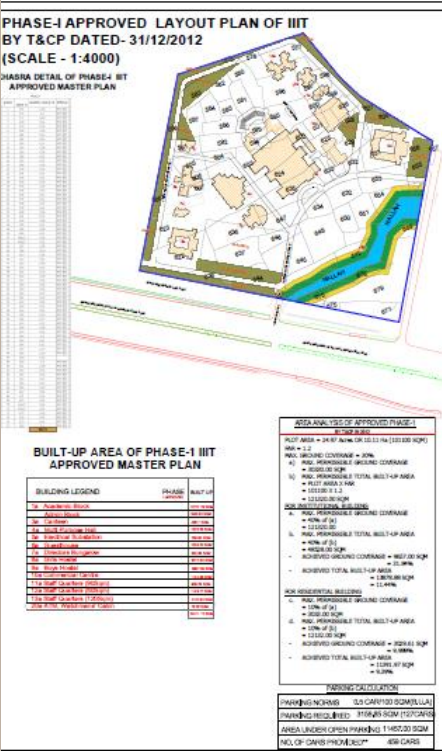
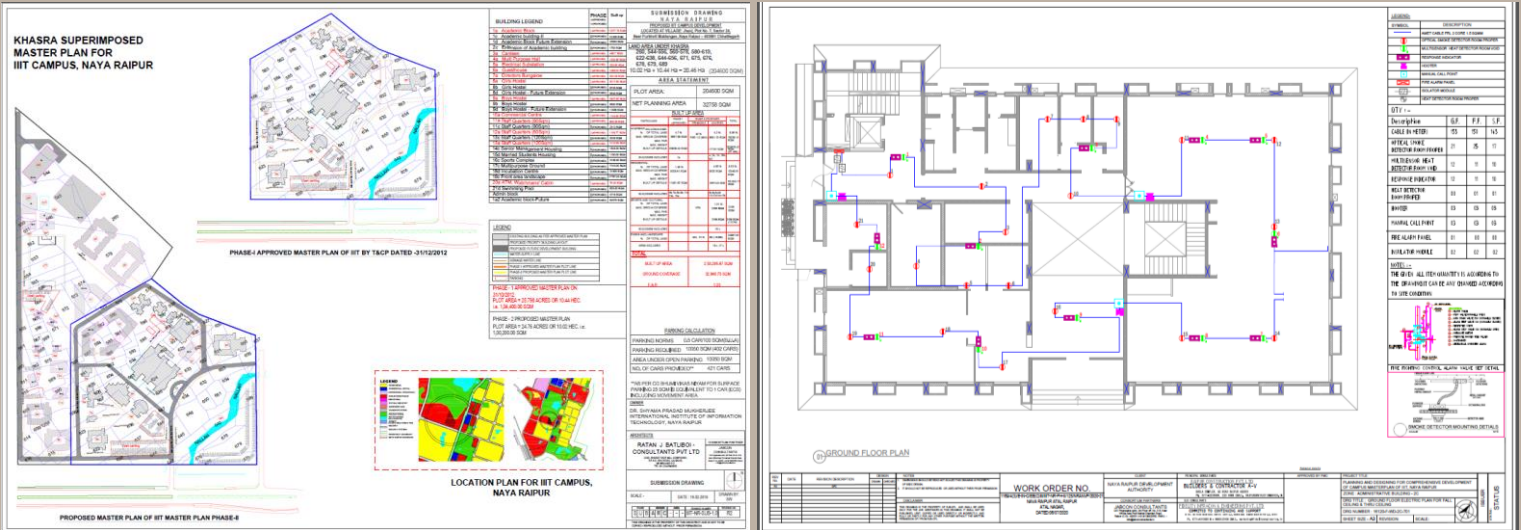

File Name	Date	Time	Format	Size
DXF BUILD_ACADEMIC BLOCK EXTENSION	2/13/2019	11:10 AM	AutoCAD Drawing...	7,484 KB
DXF BUILD_SENIOR HOUSING MANAGEMENT	2/13/2019	11:50 AM	AutoCAD Drawing...	23,224 KB
DXF BUILD_STAFF QUARTERS 11C	2/13/2019	12:29 PM	AutoCAD Drawing...	9,128 KB
DXF BUILD_STAFF QUARTERS 13C	2/14/2019	11:07 AM	AutoCAD Drawing...	9,318 KB
IIIT DXF	3/1/2019	11:24 AM	WinRAR archive	9,386 KB
DXF SECTION_ELEVATION_ACADEMIC BLOC...	2/13/2019	11:14 AM	AutoCAD Drawing...	5,997 KB
DXF SECTION_ELEVATION_SENIOR HOUSING ...	2/13/2019	11:54 AM	AutoCAD Drawing...	21,868 KB
DXF SECTION_ELEVATION_STAFF QUARTERS ...	2/13/2019	12:31 PM	AutoCAD Drawing...	8,538 KB
DXF SECTION_ELEVATION_STAFF QUATER 13C	2/14/2019	11:11 AM	AutoCAD Drawing...	7,990 KB
DXF SITE_PLAN	2/14/2019	11:14 AM	AutoCAD Drawing...	13,657 KB

Online DFX files for final building permission

# Project: Statutory Approvals For NTPC WR-II Headquarter

Client: : NRDA

Duration: Feb 2017- Feb 2020

## Project Detail :

Major Role In Project :All Statutory Approvals Required For NTPC Building

Location: Naya Raipur (C.G)

Position: Consortium Architect & Laisoning Consultant

### अटल नगर विकास प्राधिकरण

पर्यावास भवन, नार्थ ब्लॉक, सेक्टर-19 अटल नगर, जिला-रायपुर (छ.ग.) 492002  
फोन नं. 0771-2511500, फैक्स नं.0771-2511400 ई.मेल-cco@atalnagar.gov.in

संशोधन-भवन निर्माण अनुज्ञा

अटल नगर, दिनांक- 01/01/2019

क्र. 5-नि.प्र./म.नि.अ./अ.न.वि.प्र./2019,

अधिकृत हस्ताक्षरकर्ता

एनटीपीसी लिमिटेड

पश्चिम क्षेत्र-II मुख्यालय, मेनेटो आफिजो,

तीसरा एवं चौथा तल, लामाडी, जी.ई.रोड

रायपुर (छ.ग.) 492001

विषय:- भवन निर्माण अनुज्ञा बाबत।

संदर्भ:- 1. इस कार्यालय का पत्र क्रमांक 265 दिनांक 11.01.19

2. आपका आवेदन दिनांक 06.09.2018

--:oO::--

उपरोक्त संदर्भित पत्र के तारतम्य में अटल नगर सेक्टर-24, भू-खण्ड क्रमांक -87 रकबा-12994.00 वर्गमीटर पर अनुमोदित अभिन्यास अनुसार ग्राम -तृता, प.ह.न.-20, तहसील-अमनपुर, जिला-रायपुर स्थित भूमि पर कार्यालय प्रयोजन (NTPC) (phase-I) हेतु भवन निर्माण अनुज्ञा निम्नलिखित शर्तों के अधीन दी जाती है :-

1. अनुमति इस आधार पर दी जाती है कि आवेदित भूमि आवेदक के स्वामित्व/लीज/लाइसेंस के अंतर्गत आधिपत्य में है। भूमि स्वामित्व/आधिपत्य संबंधी विवाद के लिए आवेदक स्वयं जिम्मेदार होगा। सारभूत तथ्य के संबंध में कोई असत्य पाये जाने पर यह अनुज्ञा स्वमेव निरस्त मानी जावेगी।
2. किसी भी स्थिति में भवन अनुज्ञा के विरुद्ध कोई निर्माण नहीं किया जावे।
3. बाल्कनी, सीढ़ी, बाउण्ड्री वाल (With eccentric footing) आदि का निर्माण स्वयं की भूमि में किया जावे। इसके बाहर कोई निर्माण के वजह से एन.आर.डी.ए.को होने वाली क्षति की जिम्मेदारी आवेदक की होगी।
4. भवन की ऊँचाई मानचित्र अनुसार - (office block-23.55 मीटर) एवं (transit camp-17.60 मीटर) एवं (Future Office block-24.60 मीटर) से अधिक नहीं होगी।
5. फर्शी क्षेत्र अनुपात -1.10 अर्थात् मानचित्रनुसार 14320.17 वर्गमीटर से अधिक न हो।
6. भूतल अछादित क्षेत्र 18.54 प्रतिशत अर्थात् 2410.36 वर्गमीटर से अधिक नहीं होगा।
7. कुल निर्मित क्षेत्रफल निम्नानुसार होगा :-

Floors	Office Block -	Transit Camp-	Future Office Block
भूतल निर्मित क्षेत्र -	738.06 वर्गमीटर	253.03 वर्गमीटर	600.36 वर्गमीटर
प्रथम तल निर्मित क्षेत्र -	1264.24 वर्गमीटर	266.54 वर्गमीटर	608.11 वर्गमीटर
द्वितीय तल निर्मित क्षेत्र -	1421.91 वर्गमीटर	251.03 वर्गमीटर	608.11 वर्गमीटर
तृतीय तल निर्मित क्षेत्र -	1720.12 वर्गमीटर	251.03 वर्गमीटर	608.11 वर्गमीटर
चतुर्थ तल निर्मित क्षेत्र -	1652.34 वर्गमीटर	251.03 वर्गमीटर	371.11 वर्गमीटर
पंचम तल निर्मित क्षेत्र -	1570.94 वर्गमीटर	85.52 वर्गमीटर	582.36 वर्गमीटर
षष्ठम तल निर्मित क्षेत्र -	.....	.....	608.11 वर्गमीटर
सप्तम तल	.....	.....	608.11 वर्गमीटर
कुल निर्मित क्षेत्रफल	8367.61 वर्गमीटर	1358.18 वर्गमीटर	4594.38 वर्गमीटर

कुल निर्मित क्षेत्रफल - 14320.17 वर्गमीटर

8. भवन की ऊँचाई भवन अनुज्ञा के अनुसार रखा जावेगा।
9. भवन निर्माण के दौरान समस्त सुरक्षा उपायों का प्रबंध भूमि स्वामी स्वयं करेगा।
10. तड़िक चालक (Lightning-arrester) की स्थापना आपदा प्रबंध हेतु आवश्यक रूप से किया जावे।
11. भवन का निर्माण वास्तुविद/इंजिनियर की देखरेख में कराया जावे।
12. पहुँच मार्ग का विकास, परिसर का आंतरिक विकास, जल प्रदाय, जलमल निकास बिजली इत्यादि अधीनस्थाना का विकास आवेदक को स्वयं करना होगा। उपातीय खुला क्षेत्र संयुक्त संचालक नगर तथा ग्राम निवेश विभाग रायपुर द्वारा अनुमोदित मानचित्र में दर्शाये अनुसार छोड़ना होगा।

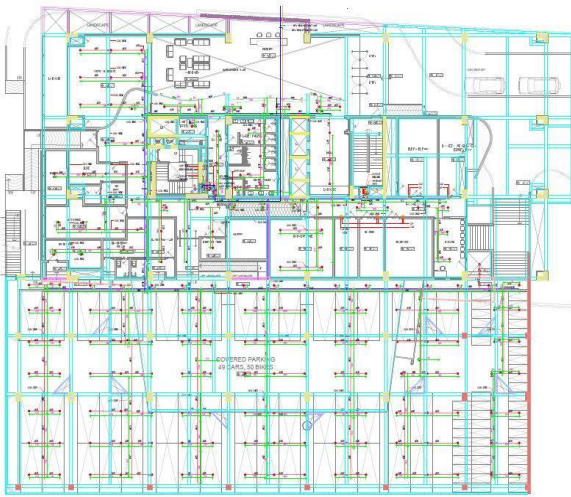
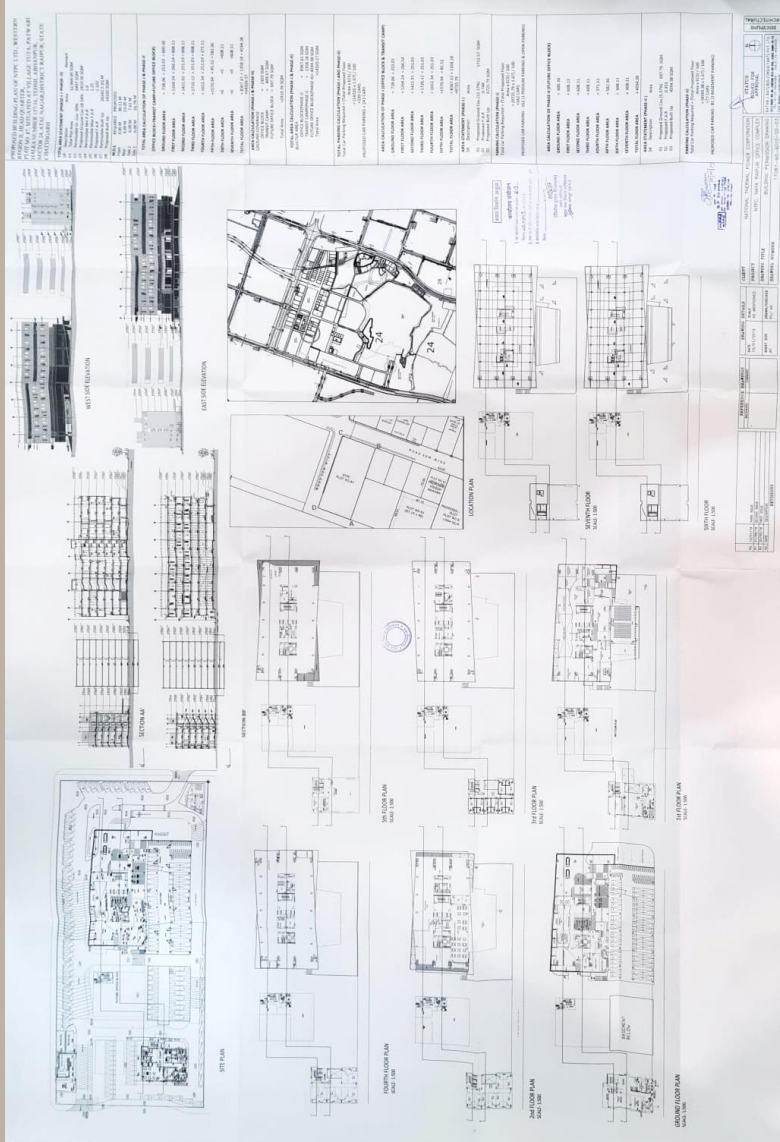

SYMBOL	DESCRIPTION
■	FIXED COLUMN
□	MOVABLE COLUMN
■	FIXED BEAM
□	MOVABLE BEAM
■	FIXED SLAB
□	MOVABLE SLAB
■	FIXED WALL
□	MOVABLE WALL
■	FIXED DOOR
□	MOVABLE DOOR
■	FIXED WINDOW
□	MOVABLE WINDOW



REVISIONS

NO.	DATE	DESCRIPTION
1	10/01/19	ISSUED FOR PERIODIC SUPERVISION

AUTHORITY: DEE VEE PROJECTS LTD. CONSULTANT: Mehta & Associates. CLIENT: NAYA RAIPUR ATAL NAGAR WEAS PROJECTS. DRAWING TYPE: O.S. GROUND FLOOR PLAN FIRE FIGHTING LAYOUT. DRAWING NO: DEEVENDA/PRJCE II/08 PLAN/01

**एनटीपीसी NTPC**  
STAGE - VII  
PERIODIC SUPERVISION DONE BY CONSORTIUM OF RJB-CPL & JABCON CONSULTANTS  
**RJB-CPL**  
JABCON CONSORTIUM  
REPORT PREPARED FOR THE PERIODIC SUPERVISION WORK  
AFTER COMPLETION OF 100% OF THE WORK ON SITE



# ARCHITECTURE , INTERIOR WORKS FOR GOVERMENT & PSU CLIENTS



**JABCON CONSULTANTS**

# COMMERCIAL PROJECTS



**Project: PRIDASRSHANI COMMERCIAL COMPLEX**

Client: Nagarpalika, Waraseoni.

Duration: 5th sep 2016

Location: Waraseoni

Position: Founder and Chief Architect Planner

**Project Detail:** Major role in the project is as follows-

- Survey Drawing.
- Submission Drawing.
- Structural Drawing
- Concept Drawing .
- Building Plan and Elevation
- 3D View

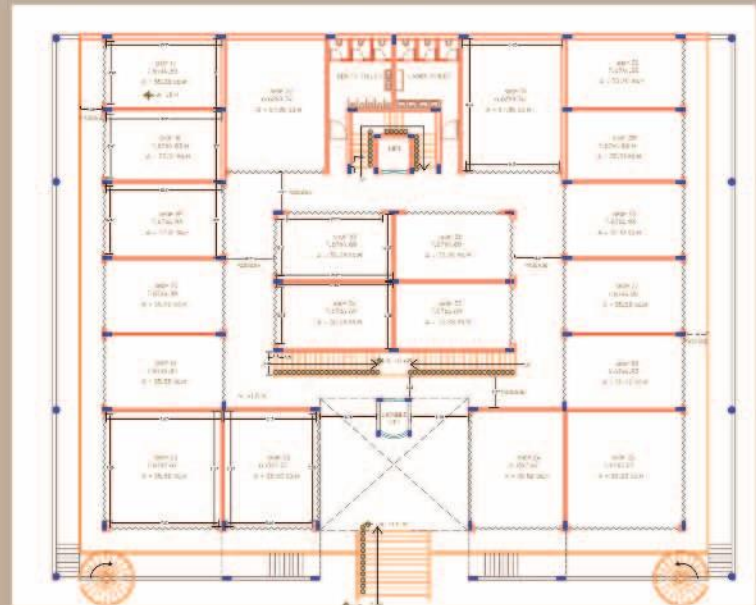
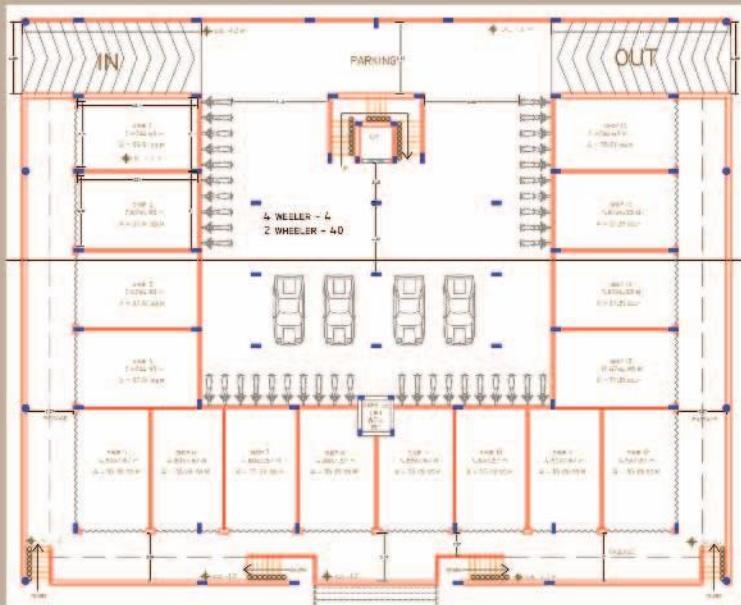

**Project: FOOD PLAZA**

Client: Nagarpalika, KATANGI.

Duration: 5th sep 2016

Location: KATANGI

Position: Founder and Chief Architect Planner

**Project Detail:** Major role in the project is as follows-

- Survey Drawing.
- Submission Drawing.
- Structural Drawing
- Concept Drawing .
- Building Plan and Elevation
- 3D View

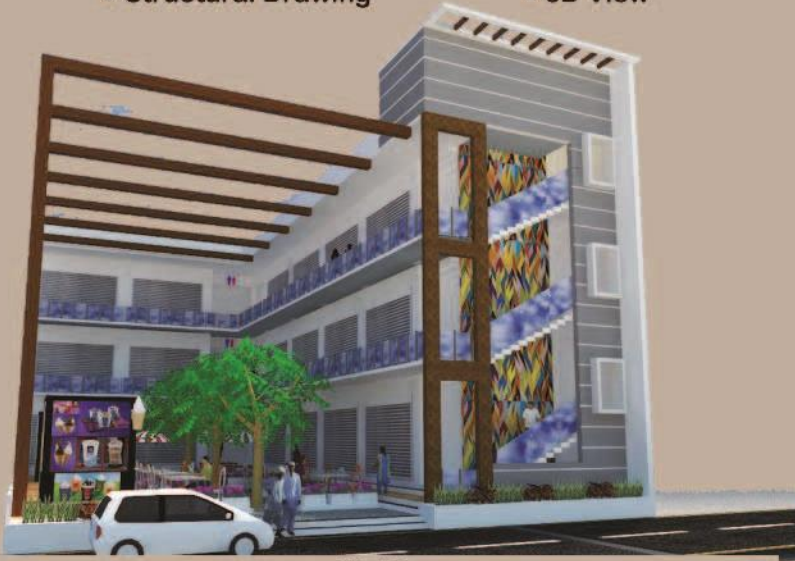

**VIEW**



**VIEW**

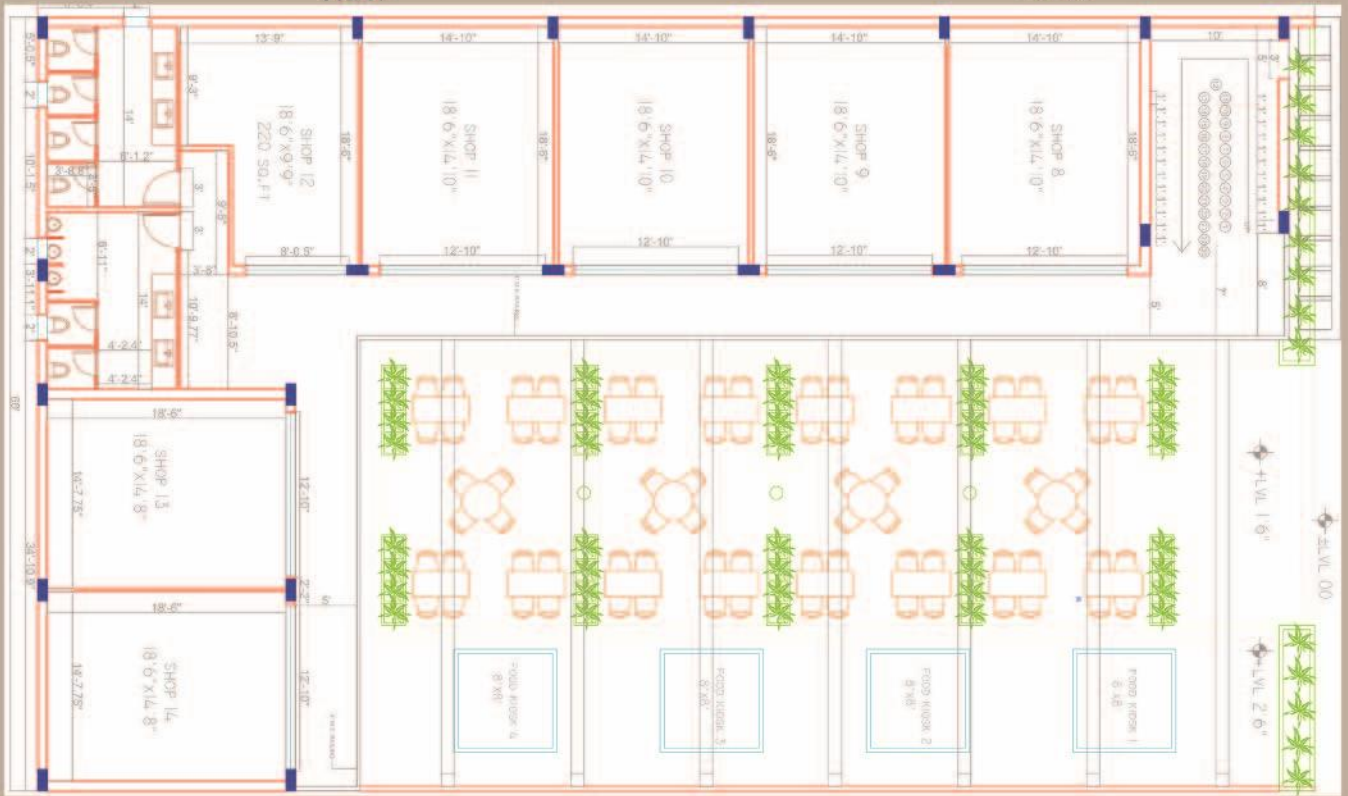

**PLAN**



**VIEW**



**VIEW**

**Project: Commercial Complex At Old Bus Stand**

Client: Ngarpalika Anuppur

Duration: 10th July 2016

Location: Anuppur

Position: Founder and Chief Architect Planner

**Project Detail:** Major role in the project is as follows-

- Survey Drawing.
- Submission Drawing.
- Structural Drawing
- Supervision services
- Concept Drawing .
- Building Plan and Ellevation
- 3D View

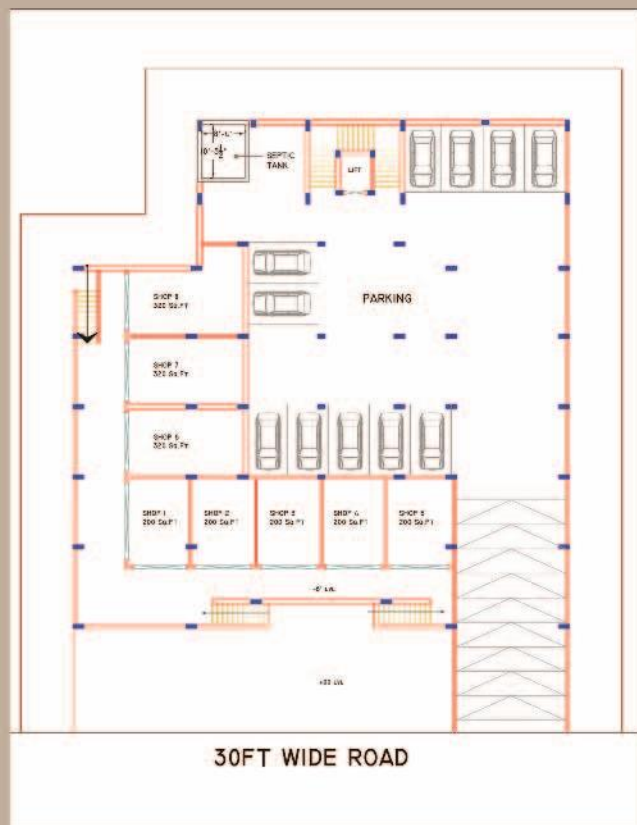
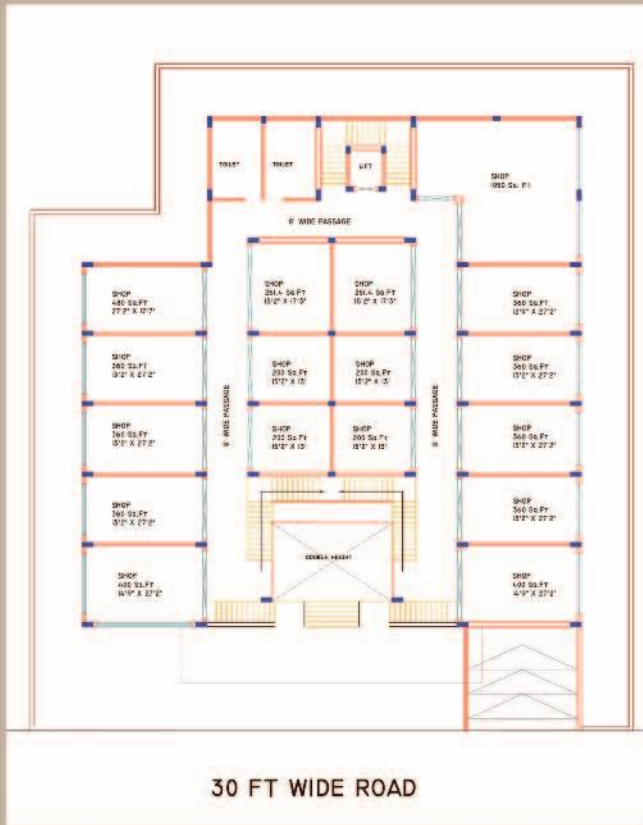

**Project: Commercial Complex Cum Municipale Council At Anuppur**

Client: Ngarpalika Anuppur

Duration: 10th July 2016

Location: Anuppur

Position: Founder and Chief Architect Planner

**Project Detail:** Major role in the project is as follows-

- Survey Drawing.
- Submission Drawing.
- Structural Drawing
- Supervision services
- Concept Drawing .
- Building Plan and Ellevation
- 3D View

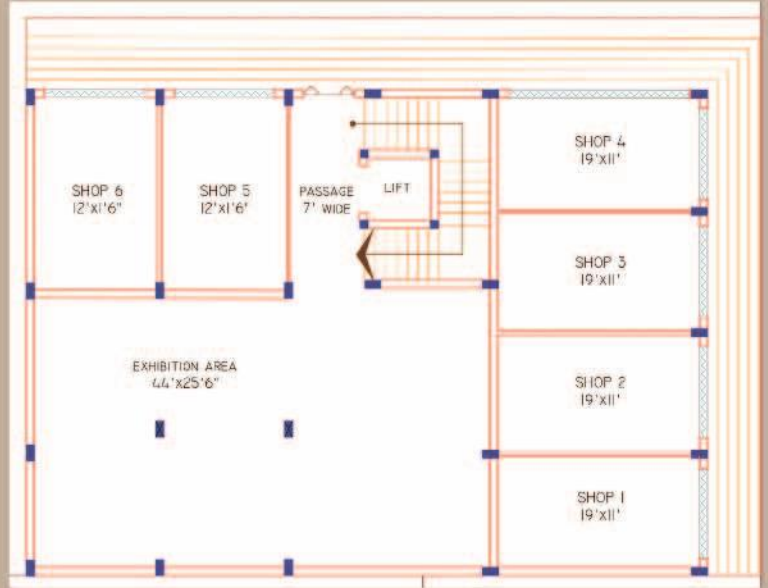
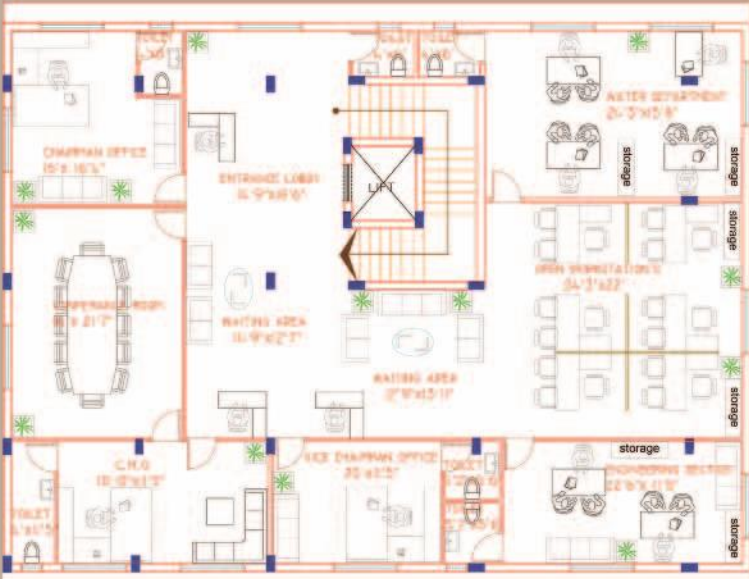

**Project: Commercial Complex At Front Side Of Nagarpalika**

Client: Nagarpalika Anuppur

Duration: 10th July 2016

Location: Anuppur

Position: Founder and Chief Architect Planner

**Project Detail:** Major role in the project is as follows-

- Survey Drawing.
- Submission Drawing.
- Structural Drawing
- Supervision services
- Concept Drawing .
- Building Plan and Elevation
- 3D View

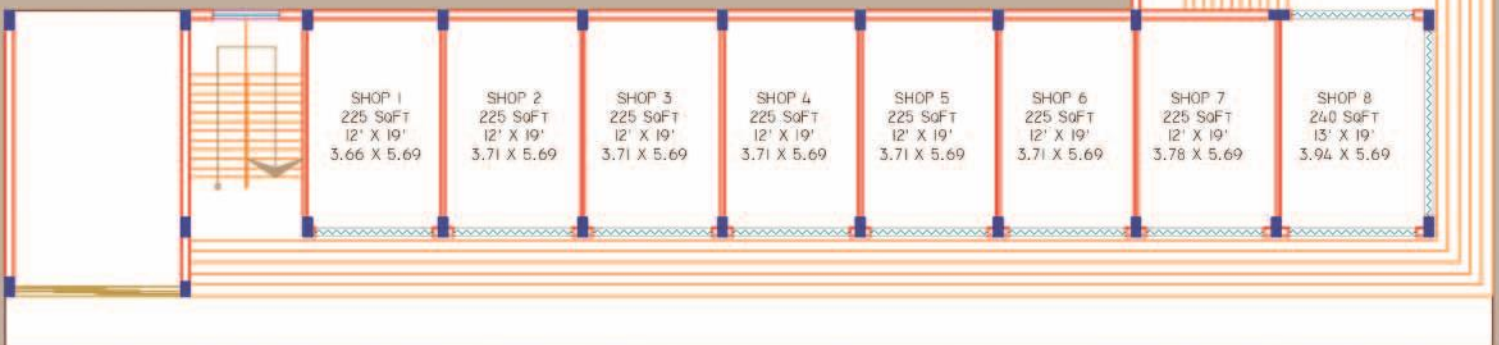

**कार्यालय नगर पालिका परिषद् अनूपपुर, जिला - अनूपपुर (म0प्र0)**

क्र0 / 1297 / न0पा0 / 2016

अनूपपुर, दिनांक - 26/7/16

प्रति,

जैबकॉन कन्सल्टेंट्स,  
तीसरा तल 318, प्रोगेशिव प्वाइंट  
रायपुर (म0प्र0)

विषय :- नगर पालिका क्षेत्रांतर्गत कार्यालय के पास कामर्शियल कॉम्पलेक्स निर्माण के लिये ड्राईंग डिजाईन प्राक्कलन तैयार किये जाने हेतु कार्यादेश।

—00—

उपरोक्त विषयांतर्गत क्रम में लेख है कि कार्यालय एवं खाली पड़ी भूमि पर कामर्शियल कॉम्पलेक्स निर्माण के लिये ड्राईंग डिजाईन प्राक्कलन तैयार करने हेतु आपके द्वारा प्रस्तुत दर न्यूनतम होने के कारण स्वीकृत की गई है।

अतः स्वीकृत दर पर कार्यालय एवं खाली पड़ी भूमि पर कामर्शियल कॉम्पलेक्स निर्माण के लिये ड्राईंग डिजाईन प्राक्कलन तैयार कर कार्यालय में प्रस्तुत करें तथा भुगतान हेतु बिल प्रस्तुत करें।

मुख्य नगर पालिका अधिकारी  
नगर पालिका परिषद् अनूपपुर  
जिला - अनूपपुर (म0प्र0)



**Project:** Proposed Commercial Complex Cum Staff Quarter At Old CMO House

**Client:** katangi nagarpanchayat

**Duration:**

**Location:** katangi

**Position:** Founder and Chief Architect Planner

**Project Detail:** Major role in the project is as follows-

- Survey Drawing.
- Submission Drawing.
- Structural Drawing
- Concept Drawing .
- Building Plan and Ellevation
- 3D View

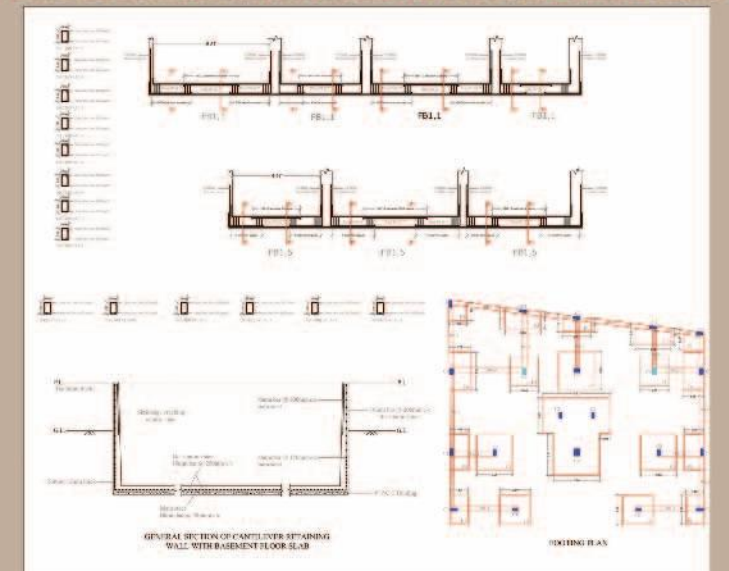
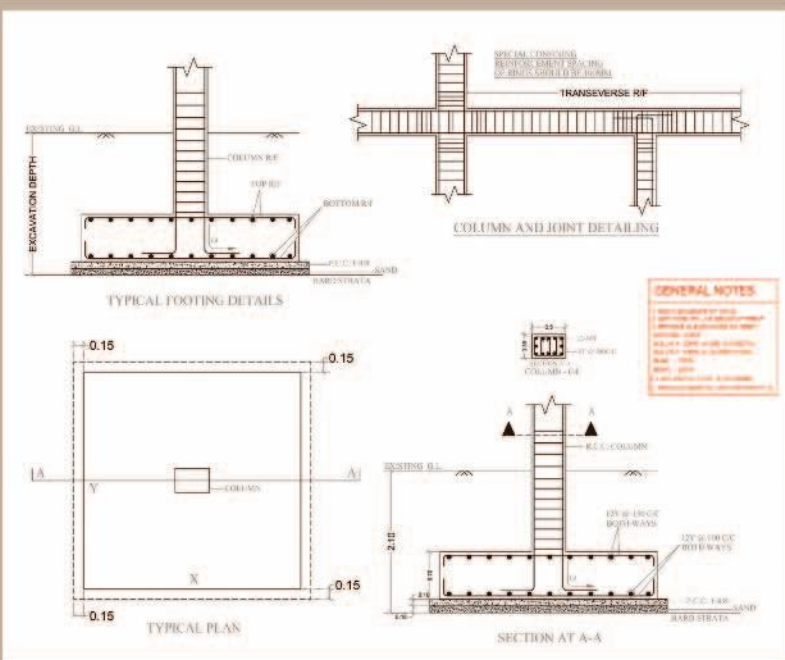
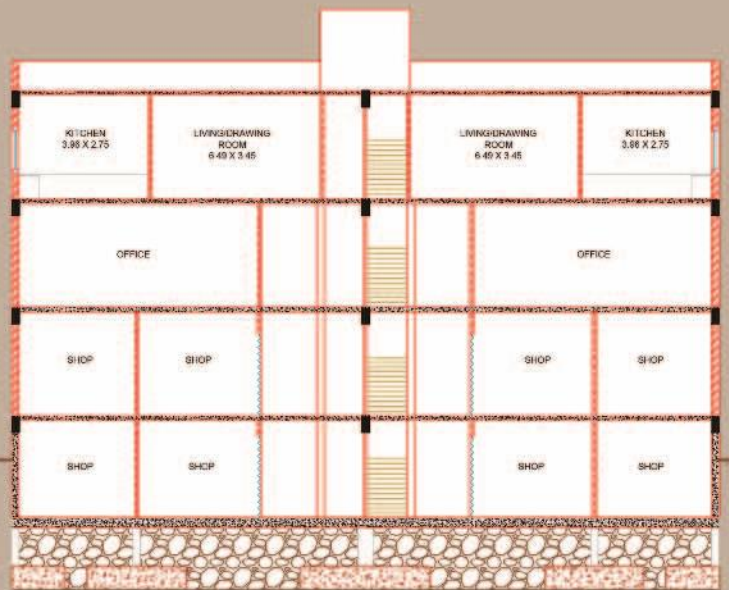
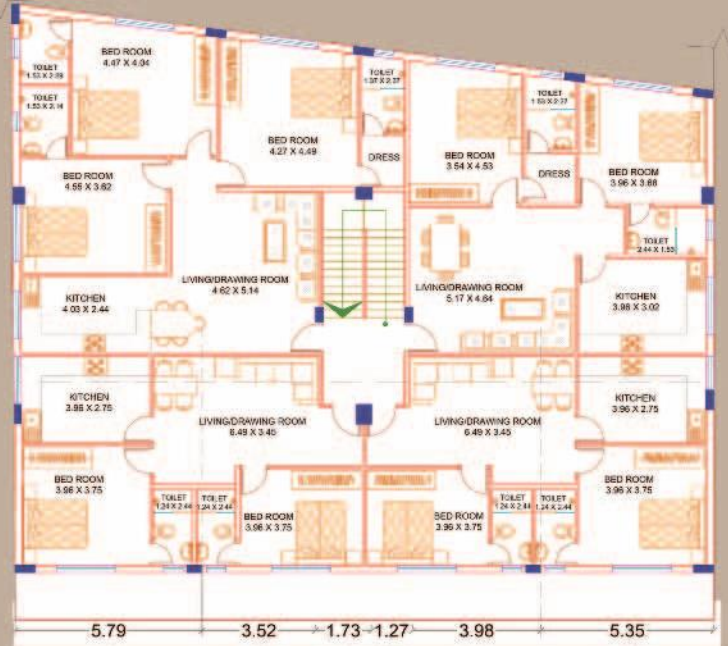
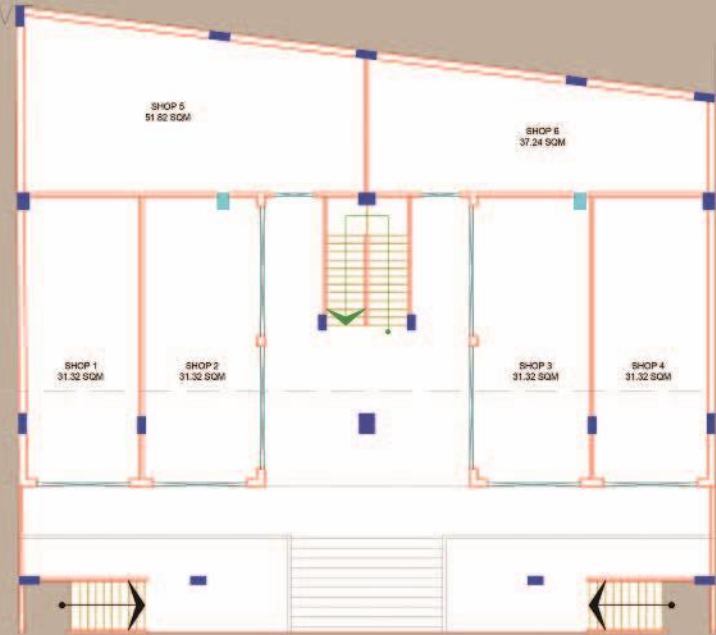



**Project: Pre School Project at Labandi,Raipur**

Client: Dinesh Tapadia

Duration:19th March 2016

Location: Raipur

Position: Founder and Chief Architect Planner

**Project Detail:** Major role in the project is as follows-

- Survey Drawing.
- Submission Drawing.
- Structural Drawing
- Concept Drawing .
- Building Plan and Elevation
- 3D View



**Project: Model School (30 Acra Campus)**

Client: Naya Raipur Development Authority

Location: Naya Raipur

Duration: 10th Jan 2016

Position: Partner Local Architect with consortium of  
RSA, Design INC Design pod, Mumbai

**Project Detail:** Major role in the project is as follows-

- Survey Drawing.
- Submission Drawing.
- Cordination During Supervision Stage
- Master Planning & Concept Drawing .
- Client Liasoning



## SERVICE ORDER

<b>Invoice To</b> <b>RATAN J. BATLIBOI- CONSULTANTS PVT. LTD.</b> 233/D, Bharat Rice Mills Compound, Adjoining Hilla Tower, Dr. S.S. Rao Road, Lalbaug, Mumbai - 400 012 CIN: U45201MH2007PTC16779	<b>Voucher No.</b> <b>SO2015-16/PL008</b>	<b>Dated</b> <b>29-Jul-2015</b>
<b>Supplier</b> <b>JABCON Consultants</b> Office No. 318, 3rd Floor, Progressive Point, New Dhamtari Road, Raipur, Chhattisgarh, India.	<b>Supplier's Ref./Order No.</b> <b>Proposal dt. 27.07.15</b>	<b>Other Reference(s)</b> <b>JB14/109</b>

Description of Goods	Amount
<b>Sub Consultancy</b> <i>For Liasoning Work</i>	<b>5,00,000.00</b>
<i>Service Tax 14%</i>	<b>70,000.00</b>
<b>Total</b>	<b>₹ 5,70,000.00</b>

Amount Chargeable (in words) E. & O.E

**Indian Rupees Five Lakh Seventy Thousand Only**

*Remarks:*  
Appointed towards Liasoning work for Reserve Bank of India site at Naya Raipur. Payments to be made upon receipt of corresponding paymnet from client.

for RATAN J. BATLIBOI- CONSULTANTS PVT. LTD.

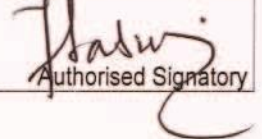
  
Authorised Signatory

## SERVICE ORDER

Invoice To <b>RATAN J. BATLIBOI- CONSULTANTS PVT. LTD.</b> 233/D, Bharat Rice Mills Compound, Adjoining Hilla Tower, Dr. S.S. Rao Road, Lalbaug, Mumbai - 400 012 CIN: U45201MH2007PTC16779	Voucher No. <b>SO2014-15/PL028</b>	Dated <b>28-Oct-2014</b>
Supplier <b>JABCON Consultants</b> Office No. 318, 3rd Floor, Progressive Point, New Dhamtari Road, Raipur, Chhattisgarh, India.	Supplier's Ref./Order No. <b>Proposal dt. 21.10.2014</b>	Other Reference(s) <b>JB14/109</b>

Description of Goods	Amount
<b>Sub Consultancy</b>	<b>1,98,000.00</b>
<i>Service Tax @ 12%</i>	<b>23,760.00</b>
<i>Education Cess @ 2% on Service Tax</i>	<b>475.00</b>
<i>Secondary &amp; Higher Education Cess @1% on S.T.</i>	<b>238.00</b>
<b>Total</b>	<b>2,22,473.00</b>

Total **2,22,473.00** E. & O.E

Amount Chargeable (in words) E. & O.E  
**Indian Rupees Two Lakh Twenty Two Thousand Four Hundred Seventy Three Only**

*Remarks:*  
 Appointed towards Geotechnical Survey for Reserve Bank of India site at Naya Raipur. Fees @40% advance along with service order & balance Payments to be made on completion of work.

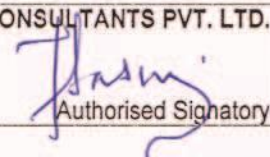
for RATAN J. BATLIBOI- CONSULTANTS PVT. LTD.  
  
 Authorised Signatory

**Project:** Caldery's DAV Public School Katni Client

**Client:** Caldery's Group Global

**Duration:** February' 2017 – February' 2019

**Location:** Katni, Madhya Pradesh

**Position:** Chief Architect Planner

**Project Detail :**

**Scope Of Work :** Total Architectural Interior Landscape And Engineering And PMC Services

**Contractor On Site :** Sita Constructions

**On Site Supervision :** PMC Services Total

**Major Role In Project :** Architect Planner As Well As PMC

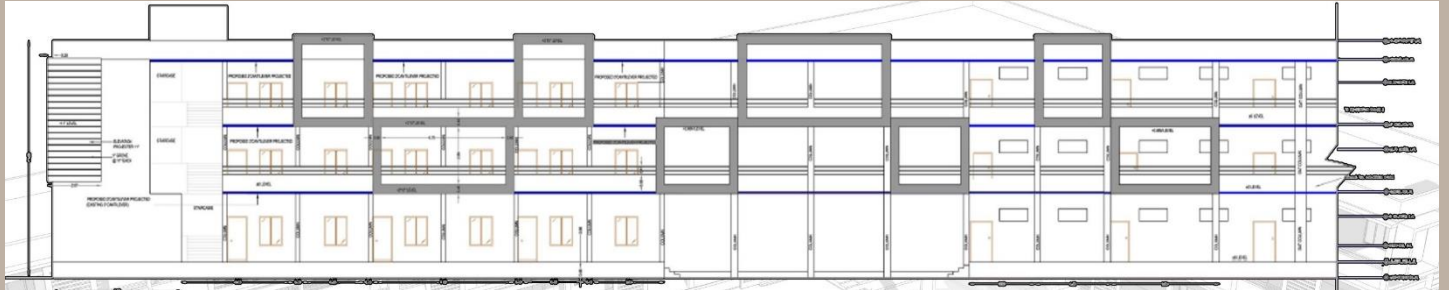

Front Elevation

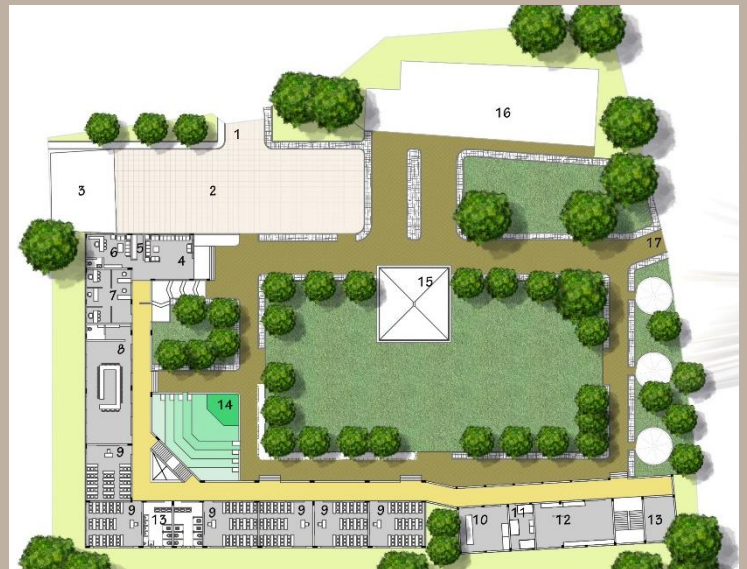

**Project:** IIIT Integrated Campus Master Planning And Building Design

**Client:** Naya Raipur Development Authority

**Duration:** August'2017 – Ongoing

**Location:** Atal Nagar, Nava Raipur, C.G.

**Position:** Consortium Master Planner & Architect

**Project Detail :**

**Scope Of Work:** - IIIT Integrated Campus Master Planning And Building Design, Nava Raipur Atal Nagar (C.G.)

**Contractor On Site:** - Raipur Construction Pvt. Ltd.

**On Site Supervision:** - Pmc: Mars Planning & Consultant

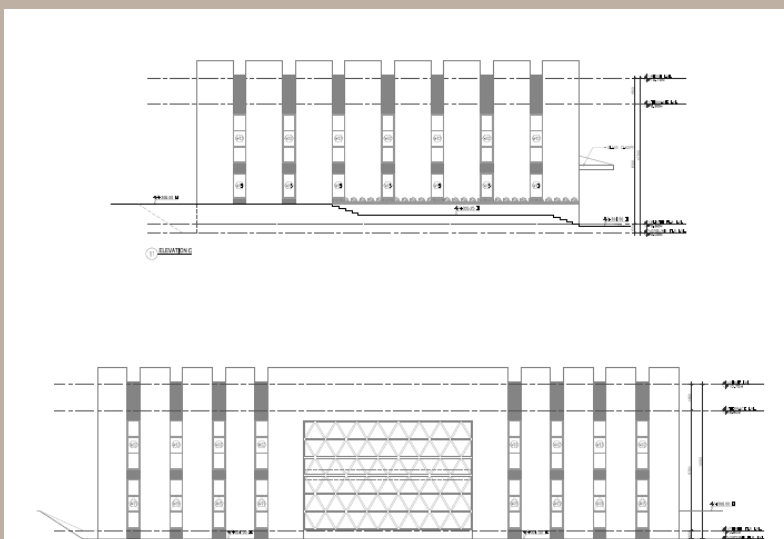
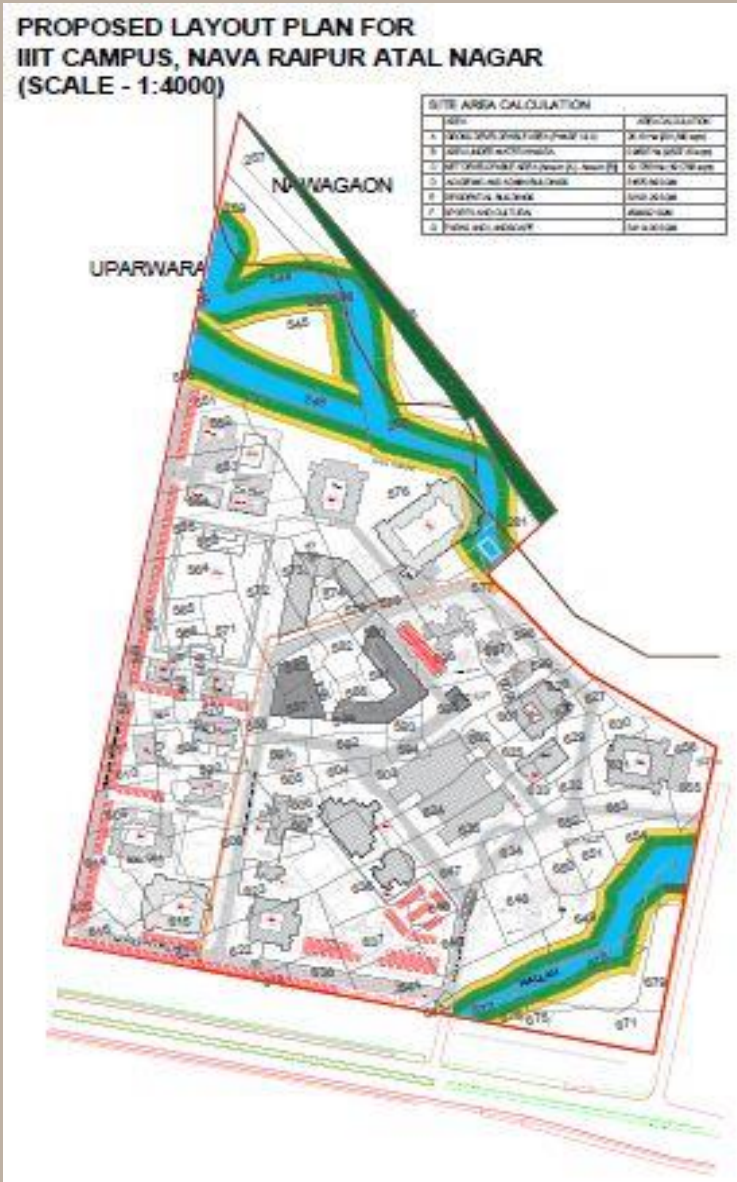



# PUBLIC SPACES



**Project:** Jatheri Lake Front Development

**Client:** Jatheri Nagar Palika

**Duration:** October 2019 – March 2021

**Location:** Madhya Pradesh

**Position:** Chief Architect Planner

**Project Detail :**

**Scope Of Work :** Total Detail Project Report

**Major Role In Project :** Design & Supervision



**MASTER PLAN DRAWING**

**SCALE INFORMATION**

1. ALL DIMENSIONS ARE IN METERS UNLESS OTHERWISE SPECIFIED.  
2. DIMENSIONS TO FACE UNLESS SPECIFIED.  
3. ALL DIMENSIONS SHALL BE BROUGHT TO THE NOTICE OF THE ARCHITECT.  
4. ALL DIMENSIONS SHALL BE BROUGHT TO THE NOTICE OF THE ARCHITECT.  
5. ALL DIMENSIONS SHALL BE BROUGHT TO THE NOTICE OF THE ARCHITECT.

NO.	REVISIONS	DATE

**LEGENDS**

- Proposed Building Footprint
- Proposed Road
- Proposed Landscaping
- Proposed Utility Lines
- Proposed Fencing
- Proposed Planting
- Proposed Water Features

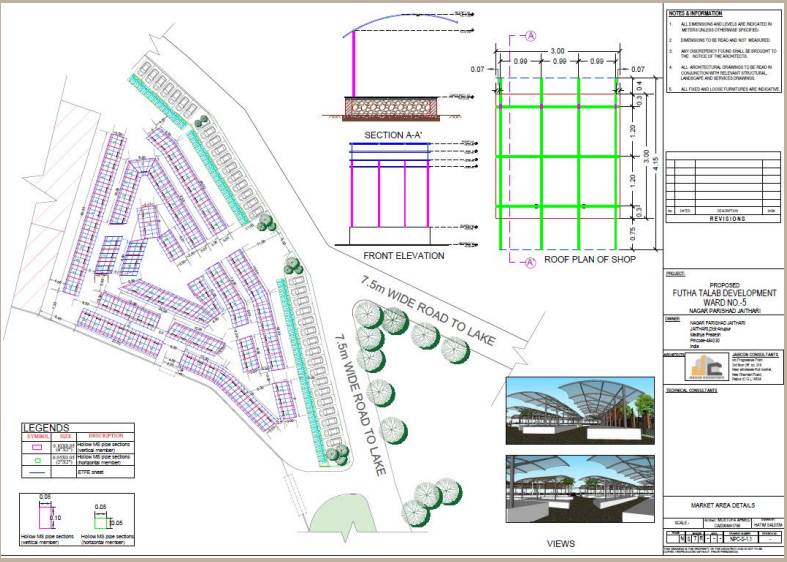

**MASTER PLAN DRAWING**

**SCALE INFORMATION**

1. ALL DIMENSIONS ARE IN METERS UNLESS OTHERWISE SPECIFIED.  
2. DIMENSIONS TO FACE UNLESS SPECIFIED.  
3. ALL DIMENSIONS SHALL BE BROUGHT TO THE NOTICE OF THE ARCHITECT.  
4. ALL DIMENSIONS SHALL BE BROUGHT TO THE NOTICE OF THE ARCHITECT.  
5. ALL DIMENSIONS SHALL BE BROUGHT TO THE NOTICE OF THE ARCHITECT.

NO.	REVISIONS	DATE

**LEGENDS**

- Proposed Compound Wall
- Proposed Fencing
- Proposed Planting

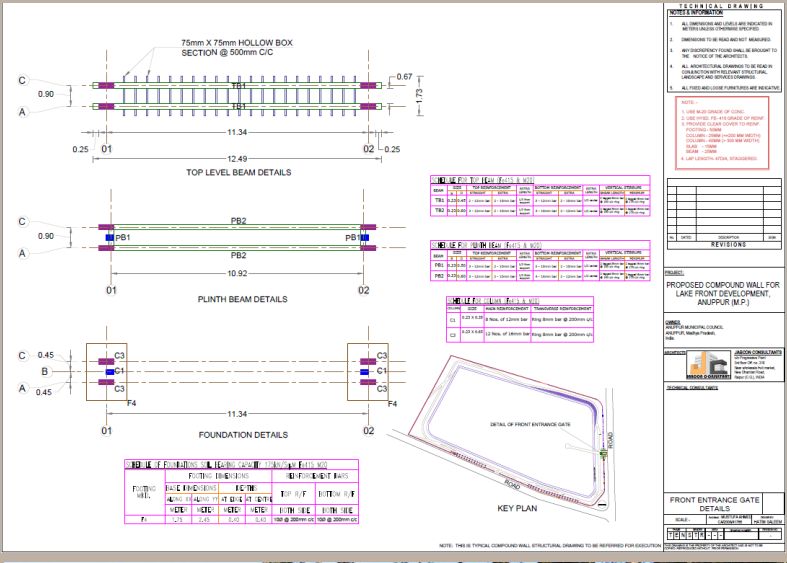

**Project: Swimming Pool Proposed For Dhanpuri Nagar Palika**

**Client: Dhanpuri Nagar Palika**

**Duration: December 2019 – April 2020**

**Location: Madhya Pradesh**

**Position: Chief Architect Planner**

**Project Detail :**

**Scope Of Work : Total Detail Project Report**

**Major Role In Project : Design & Supervision**

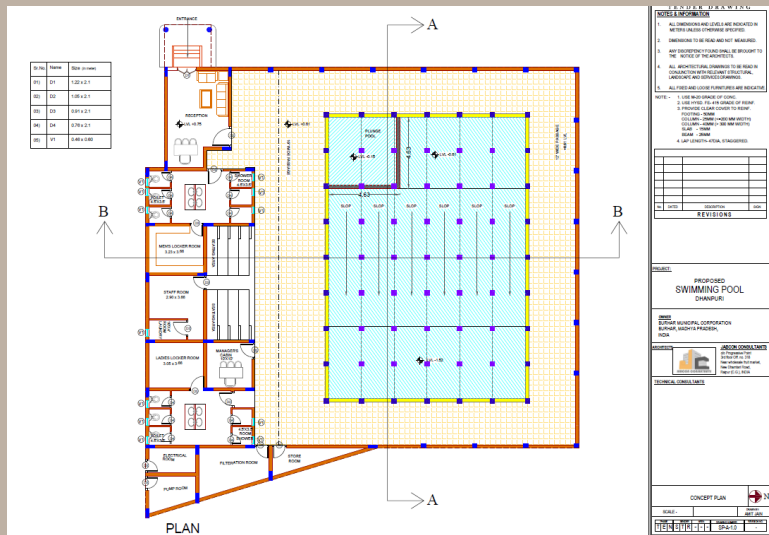
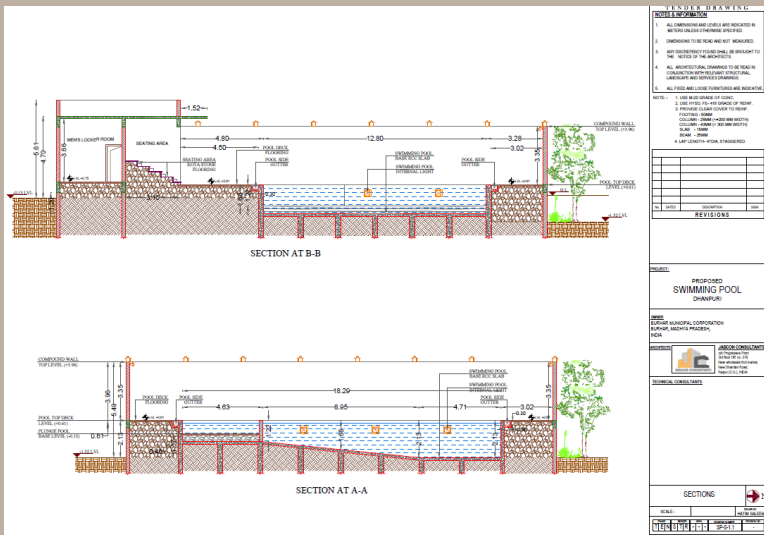

**Project:** Jaitheri Auditorium Com Marriage Hall

**Client:** Jatheri Nagar Palika

**Duration:** July 2019 – September 2021

**Location:** Madhya Pradesh

**Position:** Chief Architect Planner

**Project Detail :**

**Scope Of Work :** Total Detail Project Report

**Major Role In Project :** Design & Supervision

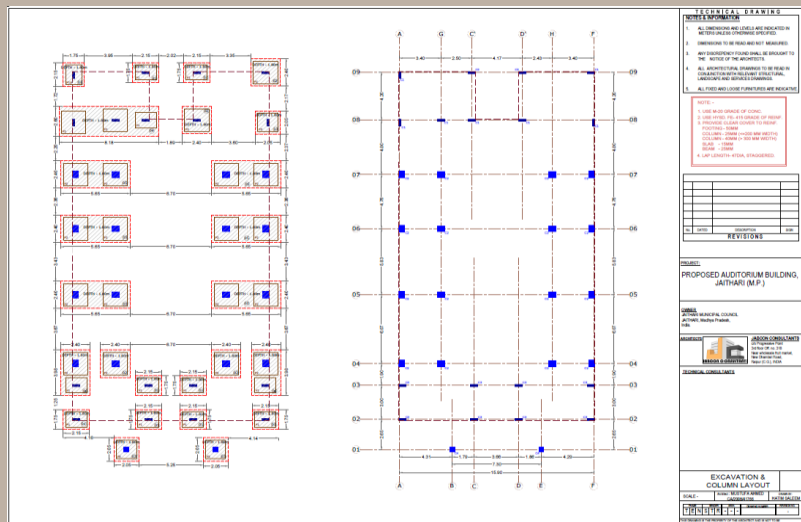
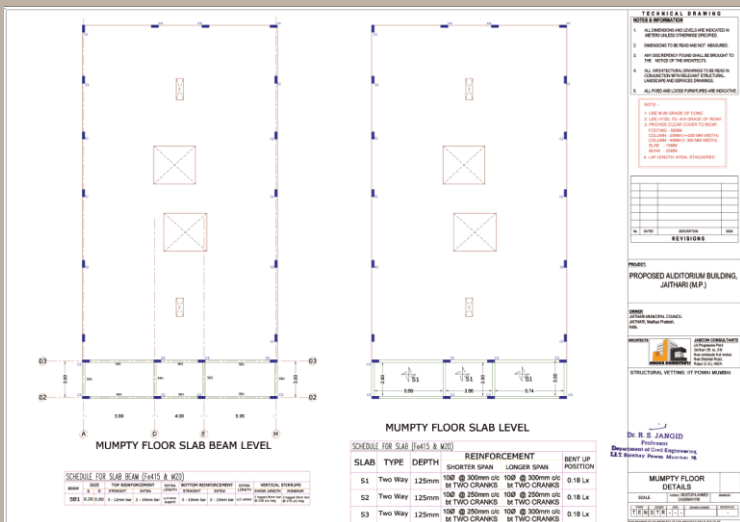
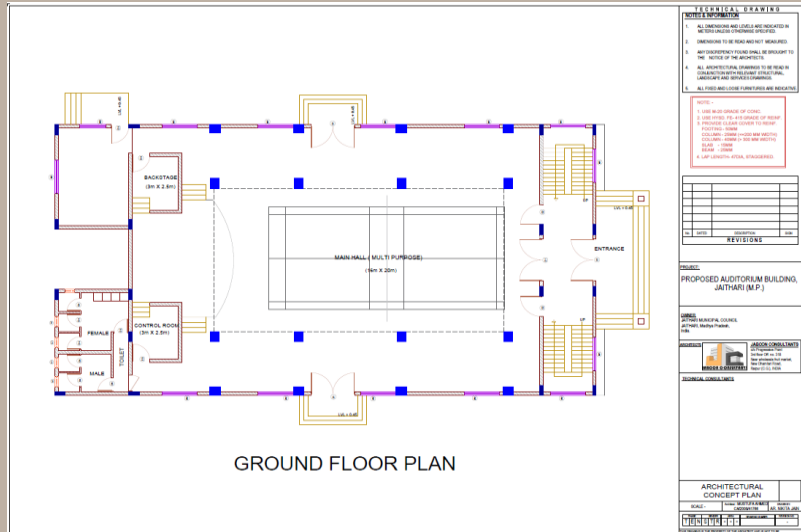
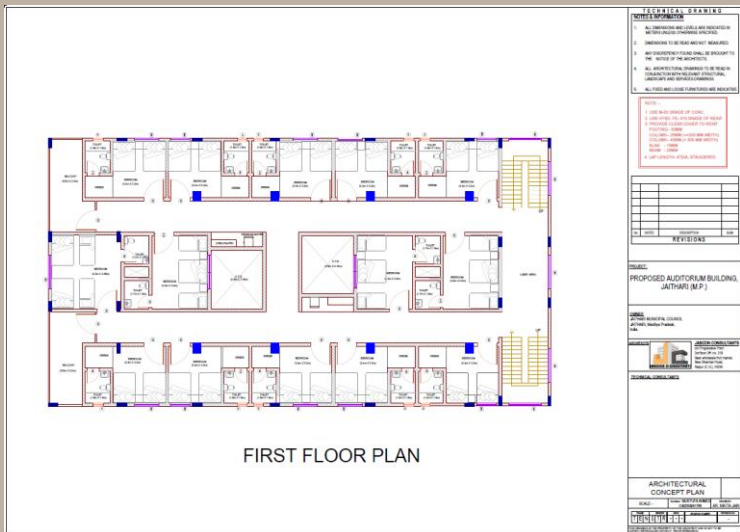

**Project: Sport Stadium, Kotma**

Client: Municipality Council, Kotma, Anuppur Dist.

Duration: 12th Feb 2015 To 5th Feb 2016

Location: Kotma

Position: Founder and Chief Architect Planner

**Project Detail:** Major role in the project is as follows-

- Survey Drawing.
- Submission Drawing.
- Structural Drawing
- Concept Drawing .
- Building Plan and Elevation
- 3D View

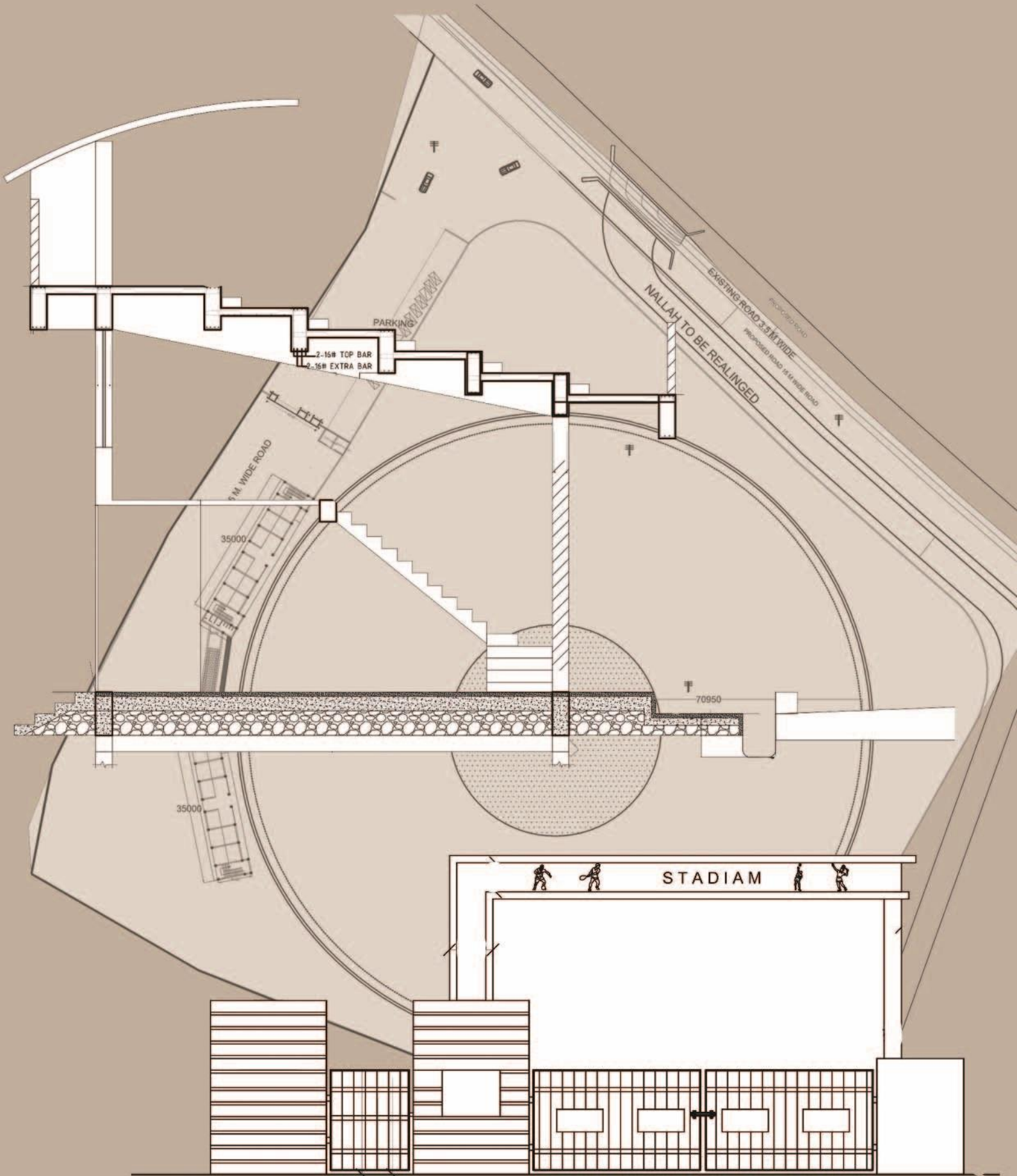

OFFICE OF MUNICIPAL COUNCIL, KOTMA, DIST- ANUPPUR, (M.P)

Date: 12.03.2015

TO,

Mr Mustufa Ahmed  
Founder & Chief Architect, Planner  
**JABCON Consultants, Raipur**

In Association with

**Tattva Design Build Pvt Ltd.**

**Subject:** Development of Community Centre, Municipal Council Office Building,  
Development of Public Park, Development of Stadium by Municipal Council, Kotma

**Ref:** Experience certificate for completion of Architectural services **Public Park , Kotma  
& Sport Stadium, Kotma**

This is to inform that Consortium of JABCON Consultants & Tattva Design Build Pvt Ltd has successfully completed Architectural Consultancy services for Public Park , Kotma

& Sport Stadium, Kotma

Following Deliverable for the both the mentioned project are submitted by consultants and approved by the Department as per below table

S. No	Name of the Project	Documents Submission
1	Public Park , Kotma	<ul style="list-style-type: none"><li>• Survey Drawings</li><li>• Concept Plans</li><li>• Submission drawings</li><li>• Building plans and elevations</li><li>• Structural Drawings</li><li>• Detail Building estimates</li><li>• 3d drawings &amp; Final view</li></ul>

2	Sport Stadium, Kotma	<ul style="list-style-type: none"> <li>• Survey Drawings</li> <li>• Concept Plans</li> <li>• Submission drawings</li> <li>• Building plans and elevations</li> <li>• Structural drawings</li> <li>• Detail Building estimate</li> <li>• 3d drawings &amp; Final View</li> </ul>
---	----------------------	---

The project cost of **Public Park , Kotma** is estimated as Rs **97.32** Lakhs & **Sport Stadium, Kotma** is estimated as **97.44** Lakhs.

The consultants have successfully completed the agreed scope of work and have received 2% fees of the estimated project cost approved by the Authority.

We wish them Luck for their future endeavours.

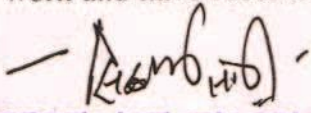
  
**ASSISTANT ENGINEER**  
**NAGAR PALIKA PARISHAD**  
**KOTMA DISTT ANUPPUR (M.P.)**  
 Assistant engineer, Kotma

for,

**Project: Public Park, Kotma**

Client: Municipality Council , Kotma ,Anuppur Dist.  
Duration: 15th Mar 2015 To 15th Feb 2016

Location: Kotma

Position: Founder and Chief Architect Planner

**Project Detail:** Major role in the project is as follows-

- Survey Drawing.
- Submission Drawing.
- Structural Drawing
- Concept Drawing .
- Building Plan and Elevation
- 3D View

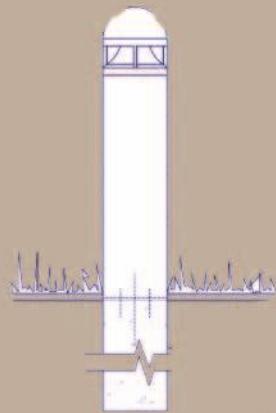
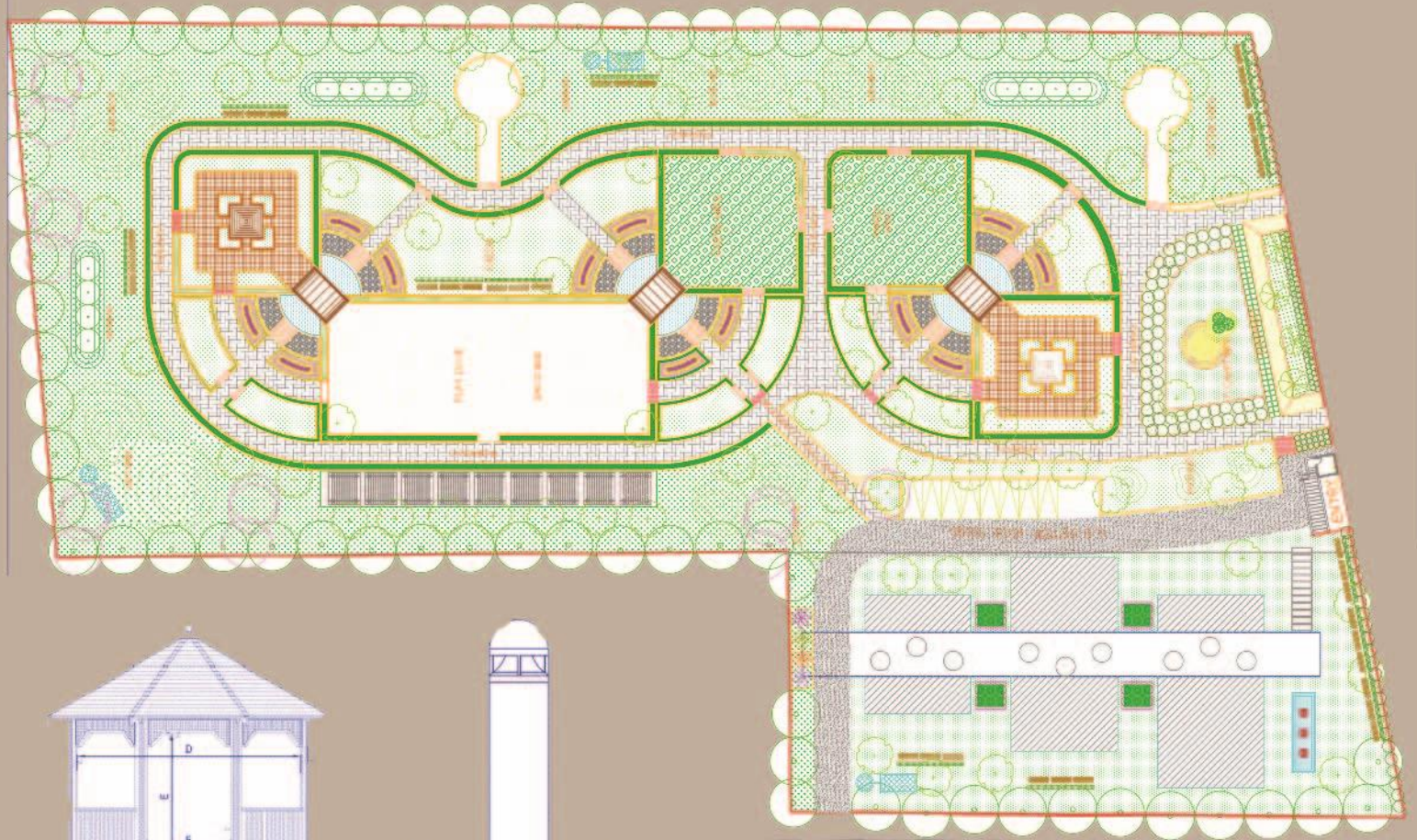
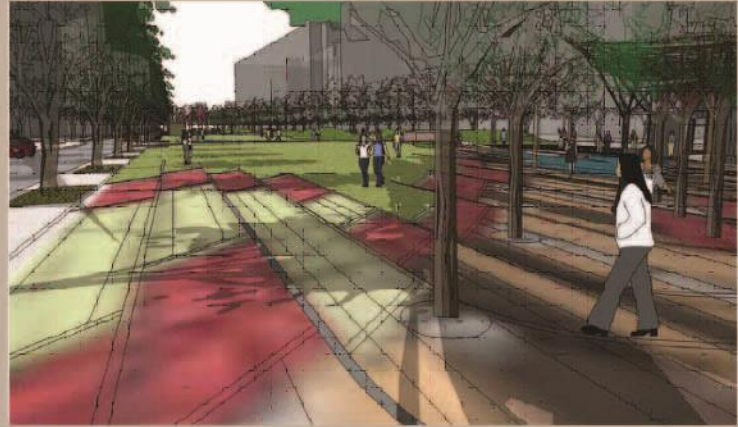



**Project: Community Center, Kotma**

Client: Municiple Council , Kotma ,Anuppur Dist.

Duration:19th Feb 2014 To 5th Nov 2014

Location: Kotma

Position: Founder and Chief Architect Planner

**Project Detail:** Major role in the project is as follows-

- Survey Drawing.
- Submission Drawing.
- Structural Drawing
- Concept Drawing .
- Building Plan and Elevation
- 3D View

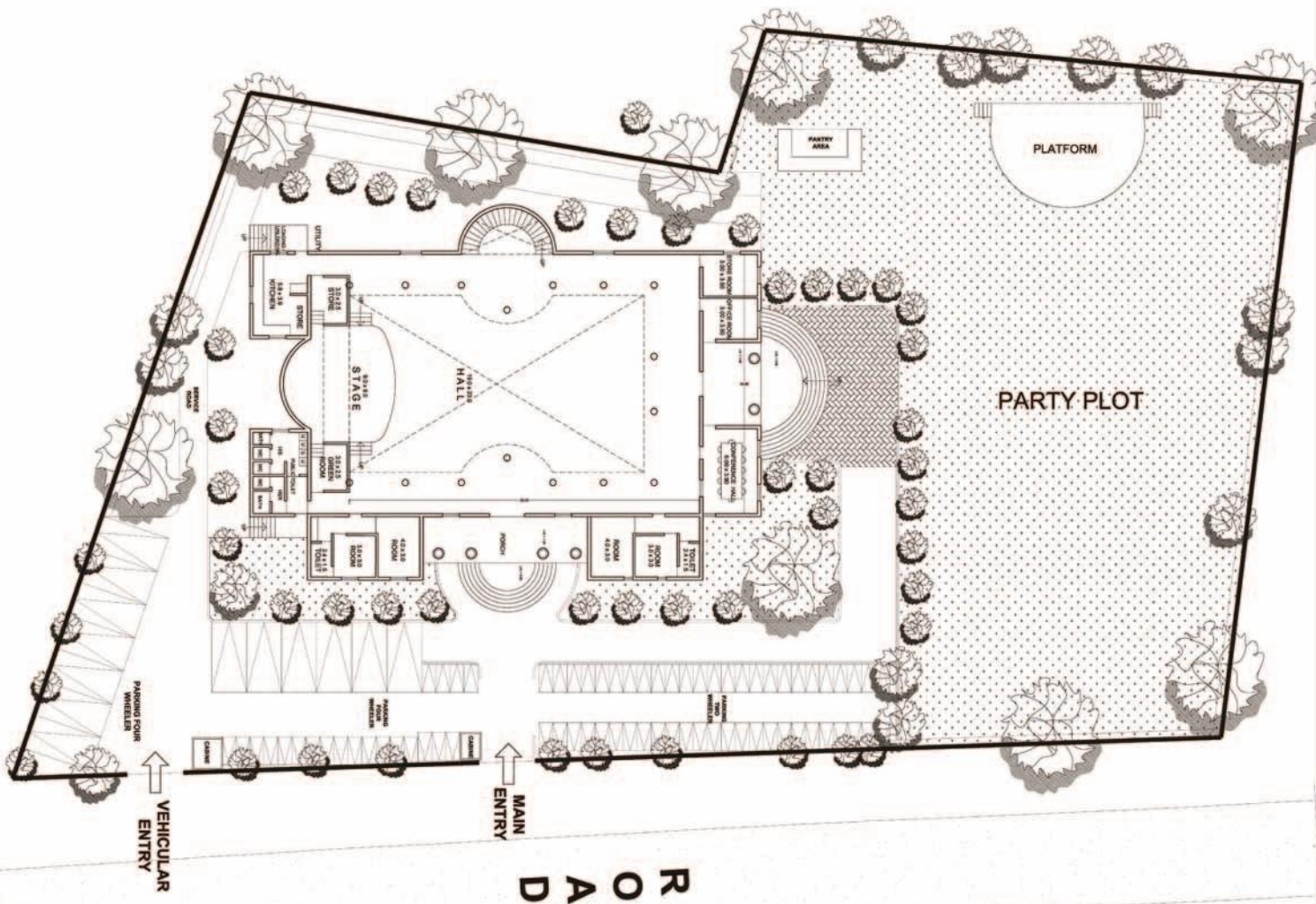

**SITE PLAN**

**Project: Community Center, Bijuri**

Client: Municiple Council , Bijuri ,Anuppur Dist.

Duration:27th Jun 2014 To 5th July 2016

Location: bijuri

Position: Founder and Chief Architect Planner

**Project Detail:** Major role in the project is as follows-

- Survey Drawing.
- Submission Drawing.
- Structural Drawing
- Supervision servies
- Concept Drawing .
- Building Plan and Elevation
- 3D View

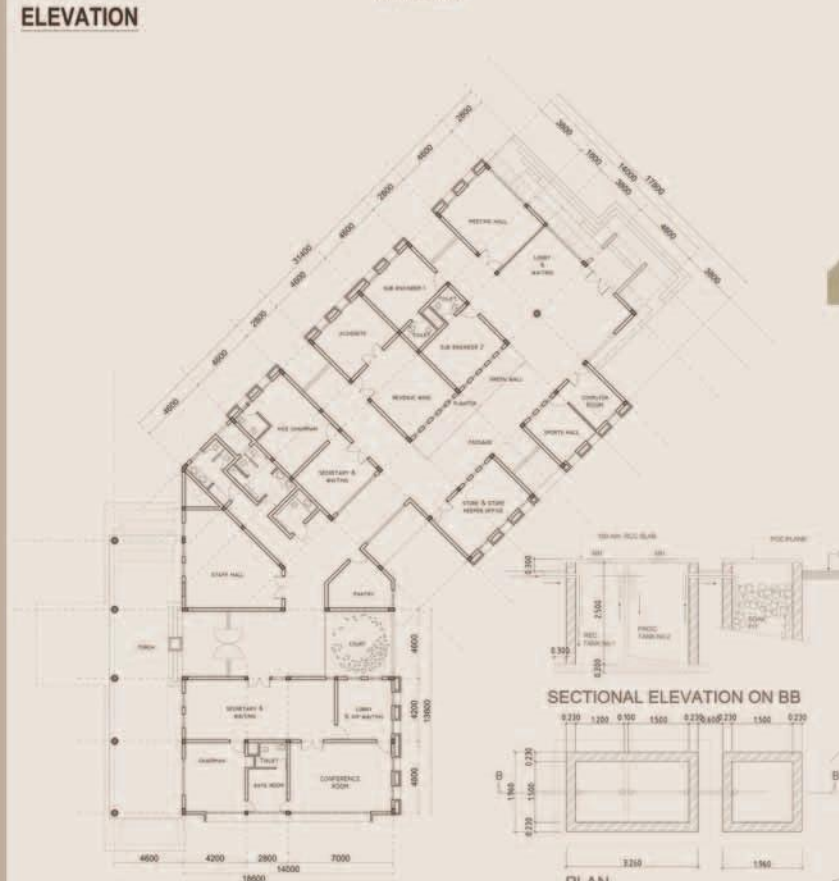
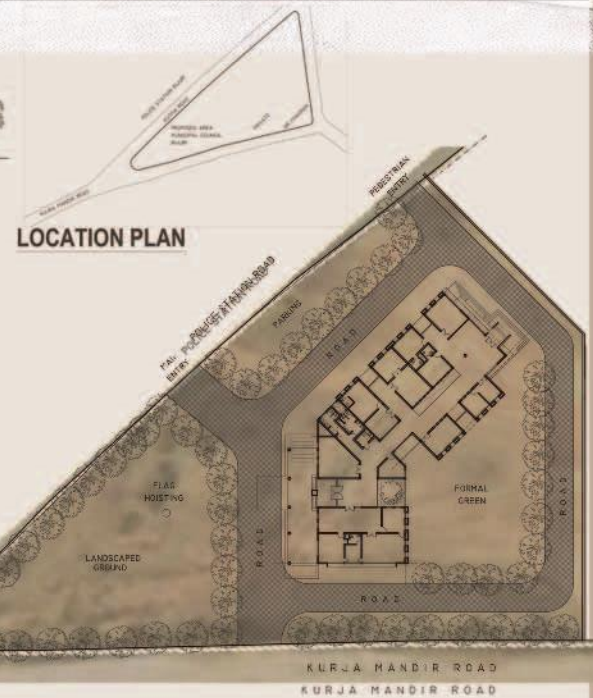

GROUND FLOOR PLAN

SEPTIC TANK DETAILS

SITE PLAN

कार्यालय नगरपालिका परिषद, बिजुरी, जिला अनूपपुर (म.प्र.)

क्रमांक : ५५ / न.पा. / लो.नि. / १४

बिजुरी, दिनांक २२/६/२०१५

प्रति,

जेबकॉन कन्सल्टेंट,  
तीसरा तल ३१८, प्रोग्रेसिव प्वाइंट,  
रायपुर (छ.ग.)

विषय : नगरपालिका क्षेत्रांतर्गत विकास कार्य कार्यालय भवन निर्माण, पार्क निर्माण  
ड्राईंग डिजाईन प्राक्कलन तैयार करने बावत् ।

एतद् द्वारा आपको आदेशित किया जाता है कि आपके द्वारा प्रस्तुत निविदा दर कार्यालय द्वारा स्वीकृत की गई । अतः आप नया कार्यालय भवन निर्माण एवं पार्क निर्माण आदि की ड्राईंग डिजाईन प्राक्कलन नगरीय प्रशासन आई.एस.एस.आर. १०.५.२०१२ से तैयार करें ।

कार्य उपरान्त आप अपना देयक बिल प्रस्तुत करें

मुख्य नगरपालिका अधिकारी  
नगरपालिका परिषद, बिजुरी  
जिला अनूपपुर (म.प्र.)

२२/६



**Project:** Municipal Council Office Building , Kotma  
**Client:** Municiple Council , Kotma ,Anuppur Dist.  
**Duration:**19th Feb 2014 To 5th Nov 2014

**Location:** Kotma  
**Position:** Founder and Chief Architect Planner

**Project Detail:** Major role in the project is as follows-

- Survey Drawing.
- Submission Drawing.
- Structural Drawing
- Concept Drawing .
- Building Plan and Elevation
- 3D View



**Project:** Extension of First Floor of Newly Build Municiple Corporation, Bijuri

Client: Municiple Council , Bijuri ,Anuppur Dist.

Location: bijuri

Duration:27th Jun 2014 To 5th July 2016

Position: Founder and Chief Architect Planner

**Project Detail:** Major role in the project is as follows-

- Survey Drawing.
- Submission Drawing.
- Structural Drawing
- Supervision servies
- Concept Drawing .
- Building Plan and Elevation
- 3D View

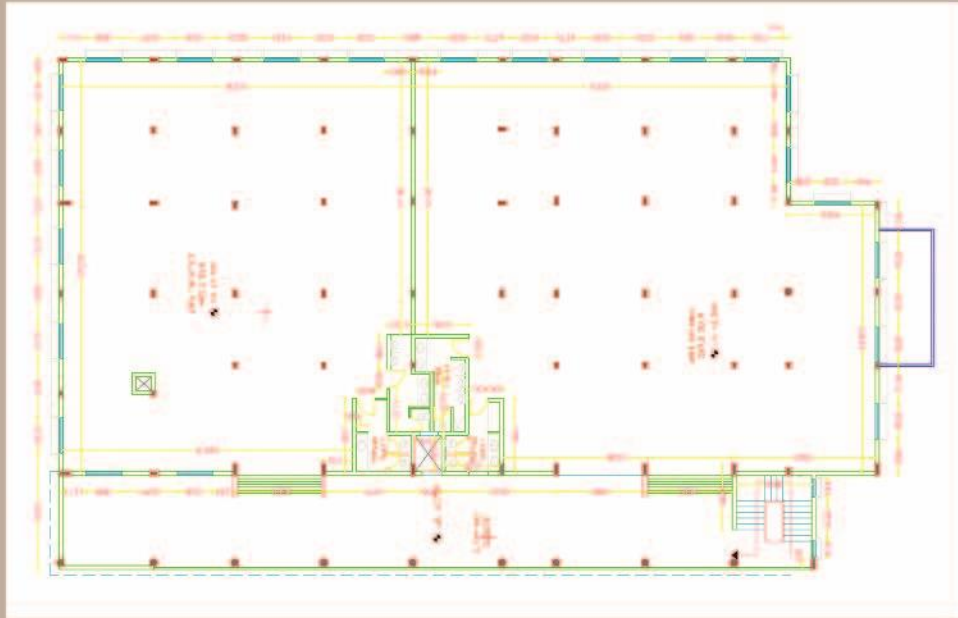

**Project: Proposed Adaptive Reuse & Interior Design for Old court Building**

Client: katangi nagarpanchayat

Location: katangi

Duration:

Position: Founder and Chief Architect Planner

**Project Detail:** Major role in the project is as follows-

- Survey Drawing.
- Submission Drawing.
- Structural Drawing
- Concept Drawing .
- Building Plan and Elevation
- 3D View

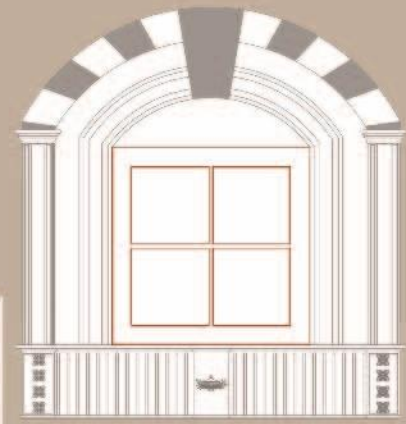

**EMERGENCY WORKS FOR PRESERVATION OF OLD COURT BUILDING**

- \* ROOF NEEDS TO BE REPLACED BY MANGLOW TILE ROOFING.
- \* BREAKING OF OLD RAISED PLINTH IS REQUIRED.
- \* EXITING WOOD WORK OF DOOR AND WINDOWS NEEDS TO BE REPAIRED AND CONSERVED.
- \* GLASS WORK FOR DOOR AND WINDOW NEED TO BE DONE.
- \* TILES NEEDS TO BE DONE BY GREEN POLISHED KOTA AND GRANITE.
- \* PLASTER OF DAMAGED PORTION NEEDS TO BE DONE.
- \* POLISHING AND PAINTING WORK NEED TO BE DONE.

**WORKS TO BE DONE FOR ADAPTIVE REUSE OF THE BUILDING AS LIBRARY FOR KATANGI TOWN**

- \* DESIGNED FURNITURE FOR LIBRARY REQUIREMENT.
- \* FALSE CEILING AND LIGHTING DESIGN.
- \* NEW MEZANINNE FLOOR FOR READING PURPOSE.
- \* CONSTRUCTION OF GENTS AND LADIES TOILETS.
- \* DECORATION OF EXITING WINDOWS WITH DESIGN MOLDING WORK FOR BEAUTIFICATION.

ROOF WORK

SECTION

DECORATION OF ELEVATION

TIMBER REPAIRING WORK

PLAN

PAINTING & POLISHING

REPAIRING WORK

DECORATION OF ELEVATION

BREAKING/LEVELING

ROOF DETAIL

PROPOSED ADAPTIVE REUSE & INTERIOR DESIGN FOR LIBRARY

CONCEPT PLANS

24TH MAY 2016

JASCON CONSULTANTS  
ARCHITECTS, ENGINEERS, DESIGNERS  
HYDRABAD, INDIA

1

SECTION

FRONT ELEVATION

SIDE ELEVATION

**GROUND FLOOR PLAN**

- 1 VERANDHA
- 2 CABIN
- 3 BOOK STORE
- 4 E-LIBRARY

**FIRST FLOOR PLAN**

- 5 READING ROOM
- 7 LADIES TOILET
- 8 GENTS TOILET
- 9 STORE ROOM

**CEILING PLAN**

PROPOSED ADAPTIVE REUSE & INTERIOR DESIGN FOR LIBRARY

CONCEPT PLANS

24TH MAY 2016

JASCON CONSULTANTS  
ARCHITECTS, ENGINEERS, DESIGNERS  
HYDRABAD, INDIA

1



रजिस्ट्रीकरण एवं स्टाम्प विभाग  
मध्य प्रदेश

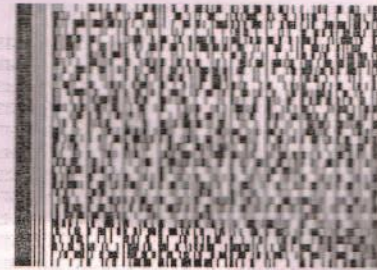

स्टाम्प शुल्क का प्रमाण पत्र

ई स्टाम्प विवरण

ई स्टाम्प कोड	01010118072016003847		
ई स्टाम्प राशि (रुपए)	1000		
शासकीय स्टाम्प ड्यूटी (रुपए)	1000	नगर पालिका ड्यूटी (रुपए)	0
जनपद ड्यूटी (रुपए)	0	उपकर राशि (रुपए)	0
छूट दी गई राशि (रुपए)	0		
ई स्टाम्प का प्रकार	गैर न्यायिक		
निर्गमन तिथि एवं समय	18/07/2016 01:07:11 PM		
यूजर आईडी / जारीकर्ता	JITENDRA KUMAR AMADARE/SP010116608201500001		
एस पी / एस आर ओ / डी आर ओ / एच ओ विवरण	WARD NO 11 BAS STAND KATANGI कटंगी बालाघाट		

डीड विवरण

विलेख का प्रकार	सहमति विलेख
लिखत	किसी प्रतिफल के बिना सहमति विलेख जो पूर्व में रजिस्ट्रीकृत या रजिस्ट्रीकृत किए जाने वाले किसी दस्ते का भाग बन गया है.-एक हजार रूपए.
उद्देश्य	सहमति पत्र

पहले पक्ष के विवरण

नाम	मुस्तुफा अहमद पुत्र/पुत्री/पत्नी/द्वारा जमील अहमद
पता	सा0तह0अकोला,बंदुकवाला इमारत तेलीपुरा चौक, जिला अकोला, महाराष्ट्र बालाघाट मध्य प्रदेश भारत
व्यक्तियों की संख्या	1

दूसरे पक्ष के विवरण

संगठन का नाम	नगर पंचायत कटंगी
पता	सा0तह0कटंगी बालाघाट मध्य प्रदेश भारत
व्यक्तियों की संख्या	1

Contract Agreement for Technical Consultant for Comprehensive Architetural service for project in Katangi Town for Municipal Conucil Katangi Dist- Balaghat

सहमति पत्र

This Agreement is made on the .....18..... day of the month of .....7/2016..... between the Municipal Council, Katangi acting through the Chief Municipal Officer, Municipal Council Katangi (hereinafter called the 'Principal' which expression shall unless excluded by or repugnant to the context be deemed to include his successors in office and assign) of the other part.

WHEREAS the Employer had invited the Consultant to provide the consultancy services (here in after called the service) and as fully described in scope of works for consultancy in Article 2 and financial offer enclosed as Appendix-II AND WHEREAS the consultant has agreed to provide services on the terms and conditions set-forth in this contract.

Now This present witness that.

**NOW THIS PRESENT WITNESS THAT THE PARTIES HAVE HEREBY AGREED HERETO AS FOLLOWS**

**ARTICLE 1 – GENERAL**

(a) For the purpose of the Agreement, the following expression shall have the meaning hereby any one duly authorized his in writing.

1.1 Date of start shall be reckoned as 10 days from the date of issue of notice to start of the actual date of start of Service whichever is earlier.

Digitally signed by Jitendra  
Kumar Amadare  
Date: 2016.07.18 13:34:04  
IST



JABCON CONSULTANTS

मुख्य नगर पालिका अधिकारी  
मुख्य नगर पालिका अधिकारी  
नगर पालिका कटंगी  
नगर पंचायत कटंगी  
बालाघाट (म.प्र.)

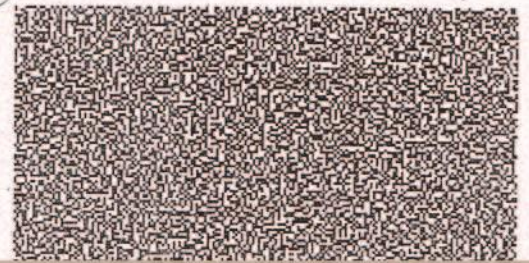



# कार्यालय नगरपालिका परिषद् बिजुरी

जिला-अनूपपुर (म.प्र.)

Ph.: 07658-264242, E-mail : cmobijuri@mpurban.gov.in, cmobijuri@gmail.com

क्र.: 1729/न.पा./लो.नि./2016

बिजुरी, दिनांक : 14.07.2016

प्रति,

जैब कॉन,कंसलटेन्ट  
नया धमतरी रोड  
रायपुर (छ.ग.) 492001

विषय- नवीन कार्यालय भवन के ऊपर प्रथम तल निर्माण हेतु ।



विषयांकित के संदर्भ में लेख है, कि निकाय क्षेत्रान्तर्गत वार्ड क्र.12 में नवीन कार्यालय भवन का निर्माण कार्य प्रगति पर है। परिषद् के प्रस्ताव द्वारा प्रथम तल पर अतिरिक्त निर्माण की मन्शा व्यक्त की गई है।

अतः आपको स्वीकृत दर पर प्रथम तल के ड्राइंग, डिजाईन, एवं सुपर विजन हेतु अधिकृत किया जाता है।

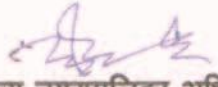
  
मुख्य नगरपालिका अधिकारी  
नगरपालिका परिषद् बिजुरी  
जिला- अनूपपुर (म.प्र.)

**Project:** NTPC Office Interior at 3rd Floor Megneto Mall Raipur

**Client:** NTPC

**Location:** Raipur

**Position:** Chief Architect Planner

**Description of Project:**

- Interior Design & Planning
- Electrical Design & HVAC Design
- Fire Fighting Design
- Detail BOQ & Estimate
- Site Supervision & Quality Reporting

**EVOLUTION OF DESIGN**

**ZONING PRINCIPALS:**

- On the main Entry, Public related spaces such as reception, Meeting rooms, Senior manager cabins and Miscellaneous cabins are placed.
- Near the main entry public meeting related and accessible spaces are provided such as Conference rooms, Meeting rooms, Audit rooms, Waiting and Cabins of senior officials are placed who will be having maximum public dealings.
- Cafeteria is placed in the area where services are easily possible and on the other side separated by the other office areas.
- Rejuvenation space has been provided at a central place between senior and junior executives for informal chats and relaxation for the comfort of staff.
- Senior executives are placed in the south west cluster with a very clear defined layout, centrally connected and easy accessible to the outside since they have public dealings.

**DESIGN PRINCIPALS:**  
Modular Design  
Open Office Design  
Economical Material Usage  
Vastu Based Interior Planning  
Resuable Design Methodology  
Minimalistic Architectural Treatment

**DESIGN EVOLUTION**

Stage 1: Existing site analysis

Stage 2: Zoning Analysis

Stage 3: Schematic concept plan

Stage 4: Detail design Stage

**Circulation Flows:**  
Public  
Services

**Birds Eye View**

Sketches of different zones of office.

**FINAL CONCEPT DESIGN**

**Miscellaneous Cabins**

**Miscellaneous Cabins**

**Rejuvenation Space**

**Workstation- Senior Executive**

**Cabins**

**Workstation- Junior Executive**

**Conference Room**

**Workstations**

**Workstation Zone**

**Canteen Zone**

**Circulation Flows:**  
Public  
Services

**LEGEND**

1. Reception
2. Audit Room
3. Meeting Room
4. Miscellaneous Cabins
5. Cabins
6. Compactors Room
7. Conference Room
8. Workstation-Junior Executive
9. Workstation-Senior Executive
10. Rejuvenation Room
11. Toilet
12. Canteen
13. Pantry
14. Kitchen
15. UPS & AHU

**FURNITURE LAYOUT**



Email-cmokatma@mpurban.gov.in

OFFICE

(07658)233260

OF THE MUNICIPAL COUNCIL, KOTMA DIST. ANUPPUR (M.P.)

No. 473/NP/PWD/2014

Kotma, Dated -23.08.2014

TO,

Mr Mustufa Ahmed  
Founder & Chief Architect Planner  
**JABCON Consultants, Raipur**  
In Association with  
**Tattva Design Build Pvt Ltd**  
*Concept*

**Subject:** Development of Community Centre, Municipal Council Office Building, Development of Public Park, Development of Stadium by Municipal Council, Kotma

**Ref:** Experience certificate for completion of Architectural services of Kotma Municipal Building & Community Centre Kotma

This is to inform that Consortium of JABCON Consultants & Tattva Design Build Pvt Ltd has successfully completed Architectural Consultancy services for Kotma Community Centre & Kotma Municipal Building.

Following Deliverable for the both the mentioned project are submitted by consultants and approved by the Department as per below table

S. No	Name of the Project	Documents Submission
1	Community Centre, Kotma	<ul style="list-style-type: none"><li>• Survey Drawings</li><li>• Concept Plans</li><li>• Submission drawings</li><li>• Building plans and elevations</li><li>• Structural Drawings</li><li>• Detail Building estimates</li><li>• 3d drawings &amp; Final view</li></ul>
2	Municipal Council Office Building, Kotma	<ul style="list-style-type: none"><li>• Survey Drawings</li><li>• Concept Plans</li><li>• Submission drawings</li><li>• Building plans and elevations</li><li>• Structural drawings</li><li>• Detail Building estimate</li><li>• 3d drawings &amp; Final View</li></ul>

The project cost of Kotma Municipal building is estimated as Rs 99.70 Lakhs & Kotma Community Centre is estimated as 98.30 Lakhs.

The consultants have successfully completed the agreed scope of work and have received 2% fees of the estimated project cost approved by the Authority.

We wish them Luck for their future endeavours.

*M/23/8/14*  
*23/8/14*  
Chief Municipal Officer, Kotma  
अन्तर बालिका परिषद, कोतमा  
जि. अनूपपुर (म.प्र.)

कार्यालय नगरपालिका परिषद्, कोतमा, जिला अनूपपुर (म.प्र.)

क्रमांक: 1052 / न.पा./लो.नि./2013-14

कोतमा, दिनांक : 19/02/14



आदेश

प्रति,

जॉब कॉम कन्सलटेंट  
एवं तत्वा कॉन्सेप्ट,  
देवेन्द्रनगर, रायपुर (छ.ग.)

विषय : नगरपालिका क्षेत्रांतर्गत विकास कार्य स्टेडियम निर्माण, भवन निर्माण, पार्क निर्माण, सामुदायिक भवन निर्माण आदि ड्राइंग डिजाइन प्राक्कलन तैयार किये जाने संबंध में ।

—0—

एतद् द्वारा आपको आदेशित किया जाता है कि आपके द्वारा प्रस्तुत निविदा दर दिनांक 04.02.2014 कार्यालय द्वारा स्वीकृत की गई है । अतः आप नगर विकास स्टेडियम निर्माण, पार्क निर्माण, कार्यालय भवन निर्माण सामुदायिक भवन निर्माण का ड्राइंग डिजाइन प्राक्कलन तैयार करें ।

कार्य उपरान्त आप अपना देयक बिल प्रस्तुत करें ।

  
मुख्य नगरपालिका अधिकारी  
MUNICIPAL COUNCIL  
कोतमा, जिला अनूपपुर (म.प्र.)

पृ. क्रमांक: 1052 / न.पा./लो.नि./2013-14

कोतमा, दिनांक : 19/02/14

प्रतिलिपि —

- 1) माननीय अध्यक्ष महोदय, नगरपालिका परिषद्, कोतमा की ओर सूचनार्थ ।
- 2) लेखापाल, नगरपालिका परिषद्, कोतमा की ओर सूचनार्थ ।



— Scd —  
मुख्य नगरपालिका अधिकारी  
MUNICIPAL COUNCIL  
कोतमा, जिला अनूपपुर (म.प्र.)

**Project:** Architectural Design And Supervision Services For NTPC WR-II Headquarters

**Client:** Naya Raipur Development Authority

**Duration:** July'2018 – February'2020

**Location:** Atal Nagar, Nava Raipur, C.G.

**Position:** Consortium Architect

**Project Detail :**

**Scope Of Work:** - NTPC WR-II Headquarters, Atal Nagar (C.G.)

**Contractor On Site:** - Dee Vee Projects Pvt. Ltd.

**On Site Supervision:** - Pmc Mehta & Associates

**Consultants:** - Consortium Of RJB-CPL & Jabcon Consultant



Google Map Of The Project



Office Building Elevational Vertical Elements

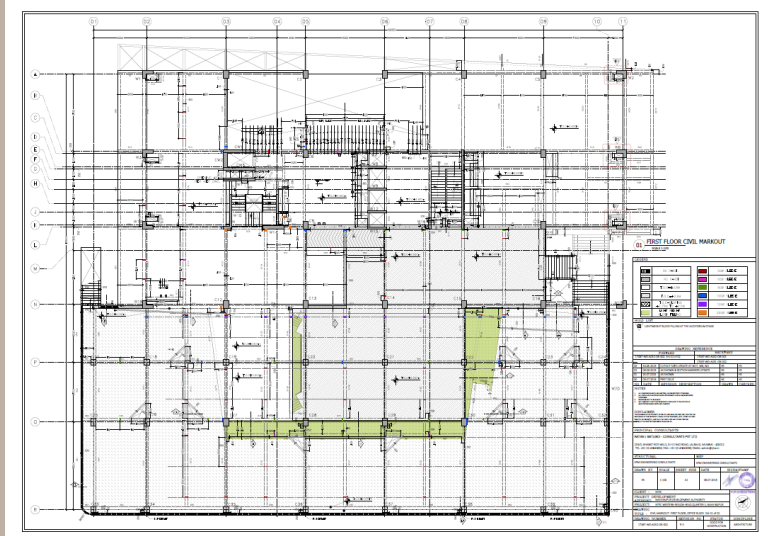

Office Building Side Elevation

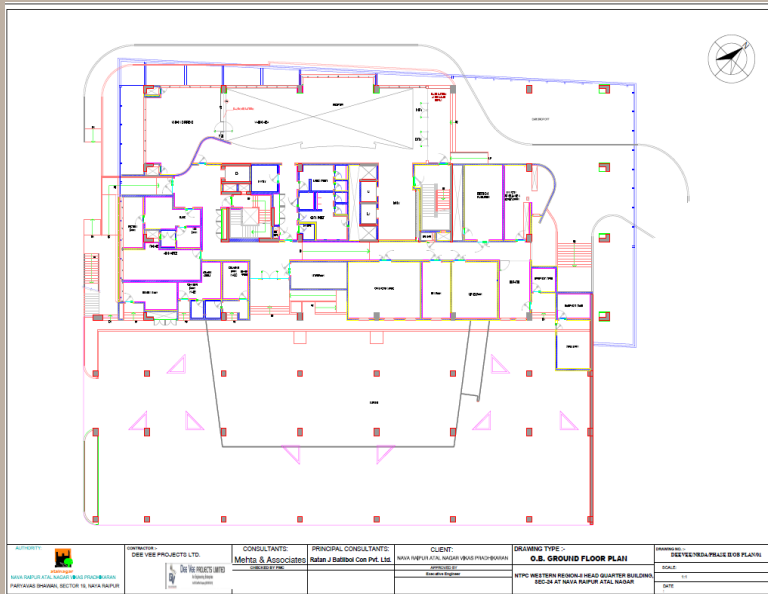

Office Building Interior Elements

# Project: Architectural Design And Supervision Services For Reserve bank Of India

Client: Reserve Bank Of India

Location: Atal Nagar, Nava Raipur, C.G.

Duration: August' 2017 - Ongoing

Position: Local Architect

## Project Detail :

**Scope Of Work:** - Architectural Engineering And Interior design & Supervision

**Contractor On Site:** - Krishna Builders , Delhi.

**On Site Supervision:** - Jabcon Consultants

**Consultants:** RJB-CPL Prime Architect & Jabcon As Local Architects

नगर सेना, अग्निशमन एवं आपातकालीन सेवाएँ तथा राज्य आपदा मोचन बल, मुख्यालय  
सेक्टर - 19 अटल नगर नवा रायपुर, जिला रायपुर (छत्तीसगढ़)

### भवन निर्माण पूर्व "अग्नि सुरक्षा प्रमाण पत्र"

क्रमांक /00/ RPR00010600 /फायर सर्विस / एन°ओ°सी° / 2023 / रायपुर

दिनांक : 08/12/2023

प्रमाणित किया जाता है कि Mr. Mustufa Jameel Ahmed द्वारा दिनांक 08/11/2023 को प्रस्तुत भवन निर्माण लेआउट प्लान एवं अग्नि सुरक्षा प्लान के अनुसार भवन निर्माण अवधि के दौरान राष्ट्रीय भवन निर्माण संहिता भाग-IV 2016 के अंतर्गत दशमि गै एग्नि निवारण एवं अग्नि से बचाव के लिए, निर्देशित उपकरणों एवं प्रणालियों को स्थापित करने एवं इसका कड़ाई से पालन करने की शर्त पर अंतिम (PROVISIONAL) अग्नि सुरक्षा प्रमाण पत्र जारी किया जाता है।

उपरोक्त निर्देशों की अवहेलना करने पर यह प्रमाण-पत्र स्वतः निरस्त माना जाएगा।



जारी दिनांक : 08/12/2023

*Muhammad*

निदेशक

दुर्गम अग्निशमन

अग्निशमन एवं आपातकालीन सेवाएँ

नगर सेना एवं नागरिक सुरक्षा, छत्तीसगढ़

प्राधिकृत अधिकारी के हस्ताक्षर

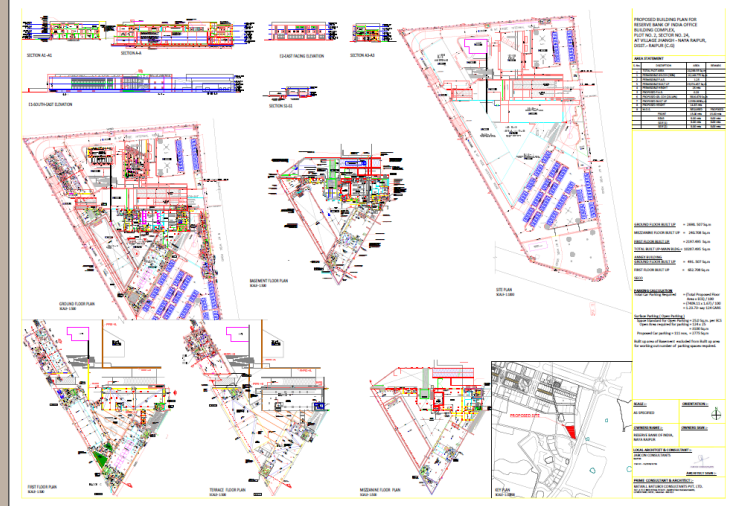

# RESIDENTIAL PROJECTS



# Project: Remodeling Of Lokhandwala Residence 100 Years Old Load Bearing Structure

Client: Shri Hussain Bhai Lokhandwala

Location: Sambhalpur, Orissa

Duration: August 2021 – April 2022

## Project Detail :

### Major Role In Project :

- Interior design services
- Architectural design services
- Supervision Services
- Concept Drawing
- Design build services
- 3D View

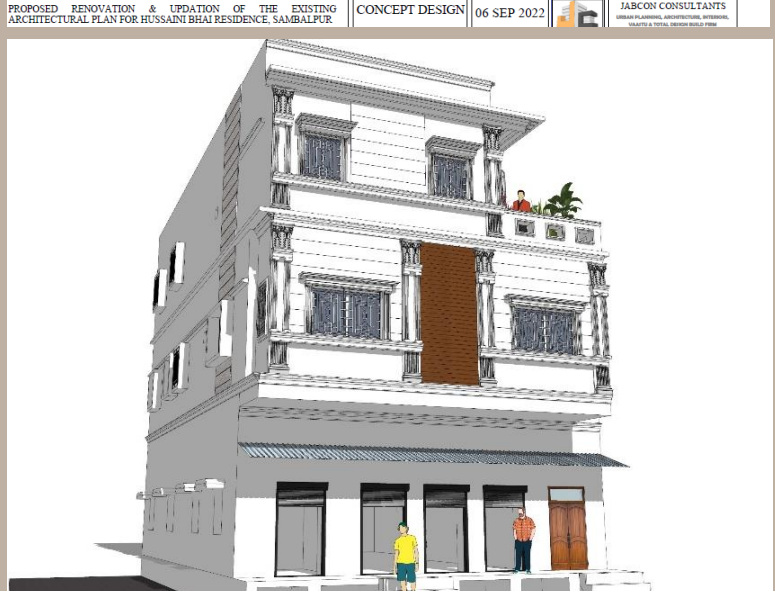
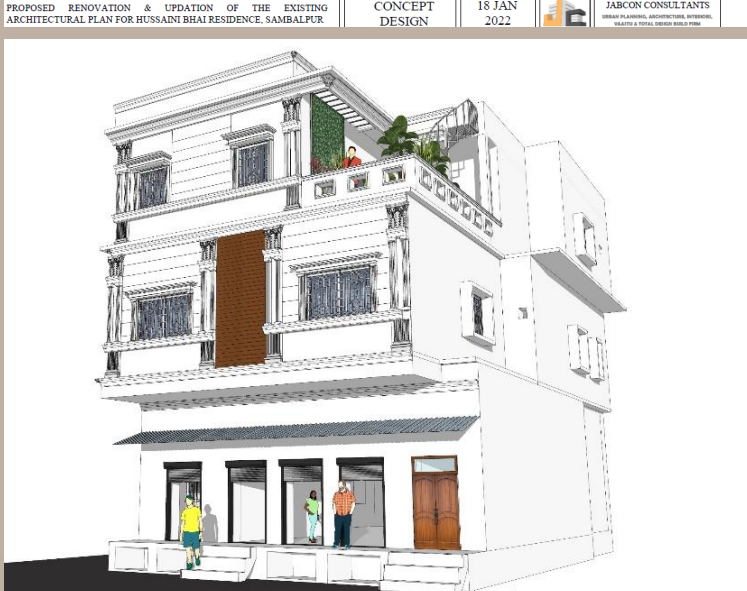
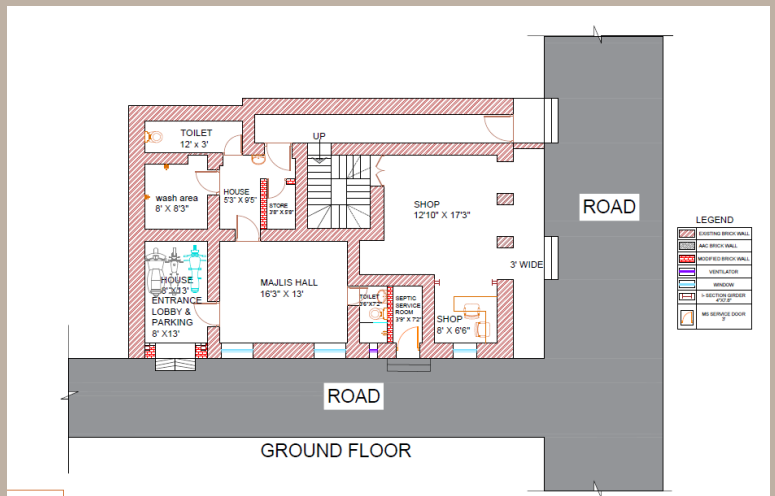
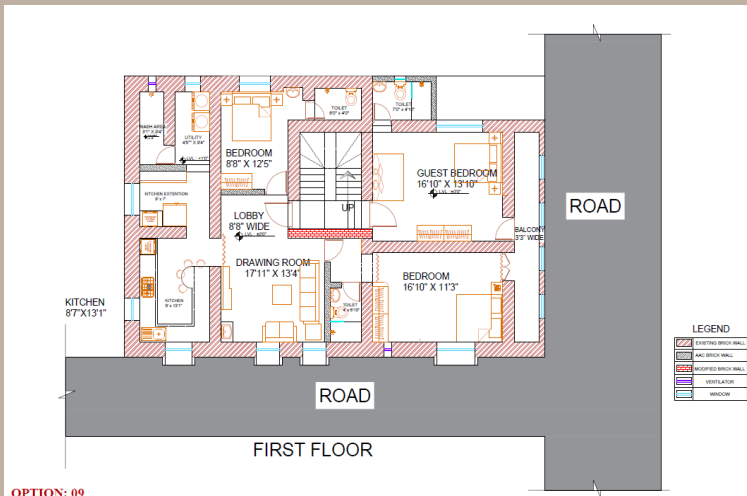



**Project :** Muffadal Villa Residence  
**Client :** Kadri Enterprises Family  
**Duration:** January 2022 - Ongoing

**Location:** Ahmed Colony, Akola  
**Position:** Chief Architect and Planner

**Project Detail :**

**Scope Of Work :** All Statutory Approvals On Behalf Of Client

**Major Role In Project :**

- Survey Drawing
- Submission Drawing
- Structural Drawing
- Supervision Services
- Concept Drawing
- Building Plan And Elevation
- 3D View

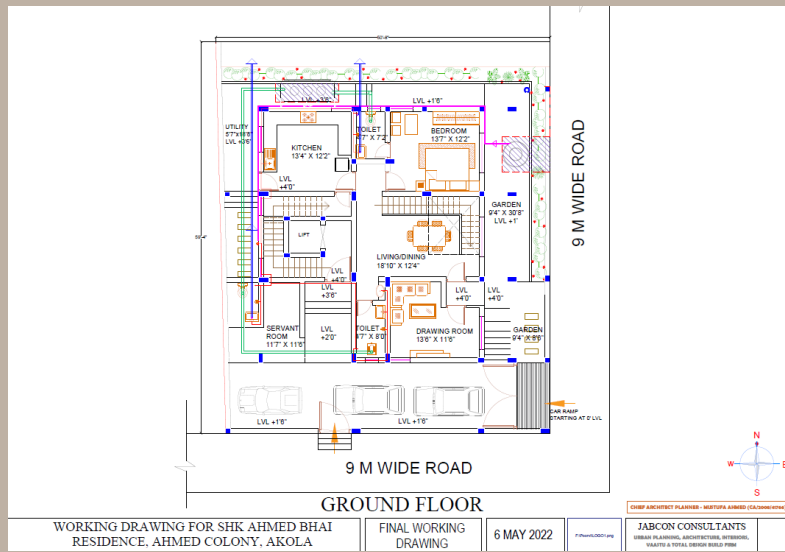
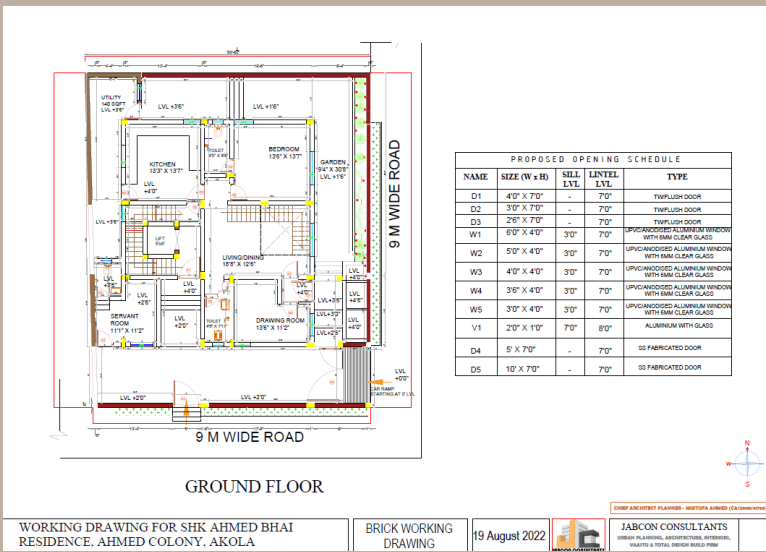

WORKING DRAWING FOR SHK AHMED BHAI RESIDENCE, AHMED COLONY, AKOLA

BRICK WORKING DRAWING

19 August 2022



JABCON CONSULTANTS  
 URBAN PLANNING, ARCHITECTURE, INTERIORS,  
 VASTU & TOTAL DESIGN BUILD TEAM

WORKING DRAWING FOR SHK AHMED BHAI RESIDENCE, AHMED COLONY, AKOLA

FINAL WORKING DRAWING

6 MAY 2022



JABCON CONSULTANTS  
 URBAN PLANNING, ARCHITECTURE, INTERIORS,  
 VASTU & TOTAL DESIGN BUILD TEAM



**Project: Residence**

Client:

Duration: 19th April 2015 to 25th July 2016

Location: Byzon Bazar

Position: Founder and Chief Architect Planner

**Project Detail:** Major role in the project is as follows-

- Survey Drawing.
- Submission Drawing.
- Structural Drawing
- Concept Drawing .
- Building Plan and Elevation
- 3D View

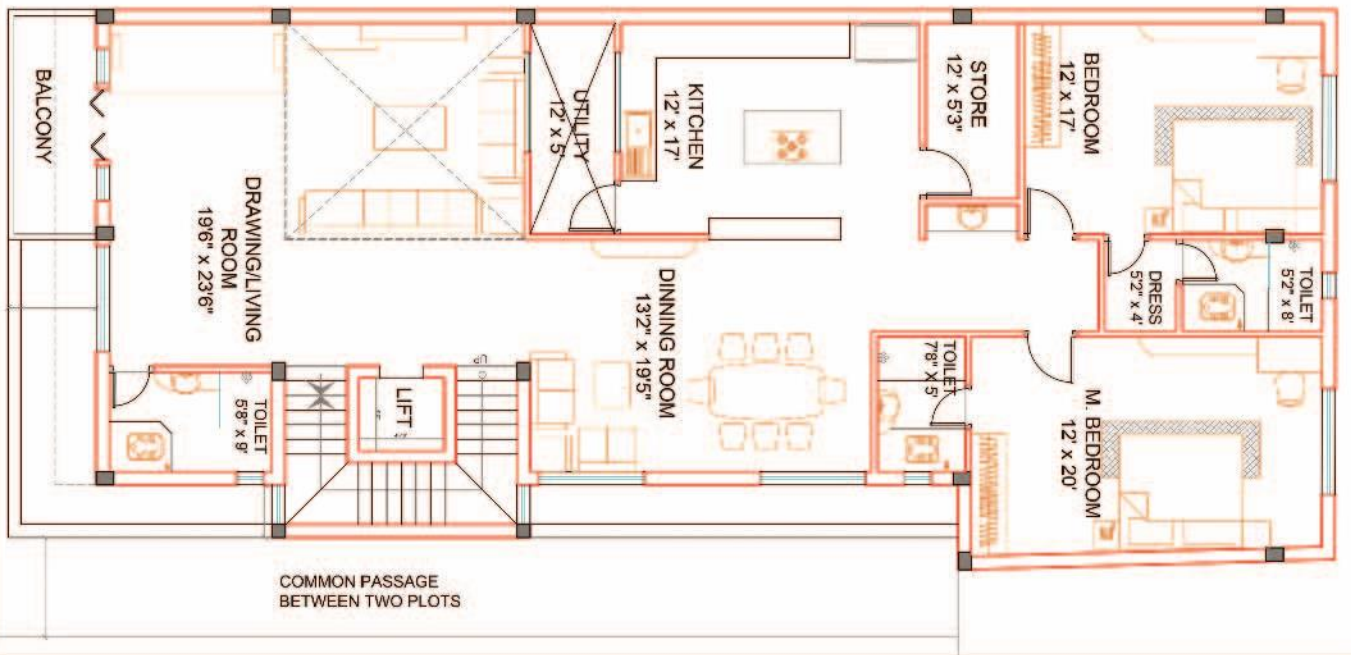

**Project:** Proposed Residence for Mr. Ali MD ACE Calderys

**Client:** Mr. Ali MD ACE Calderys

**Duration:** 17th March 2014 To 5th July 2015

**Location:** Nagpur

**Position:** Founder and Chief Architect Planner

**Project Detail:** Major role in the project is as follows-

- Survey Drawing.
- Submission Drawing.
- Structural Drawing
- Supervision services
- Concept Drawing .
- Building Plan and Ellevation
- 3D View

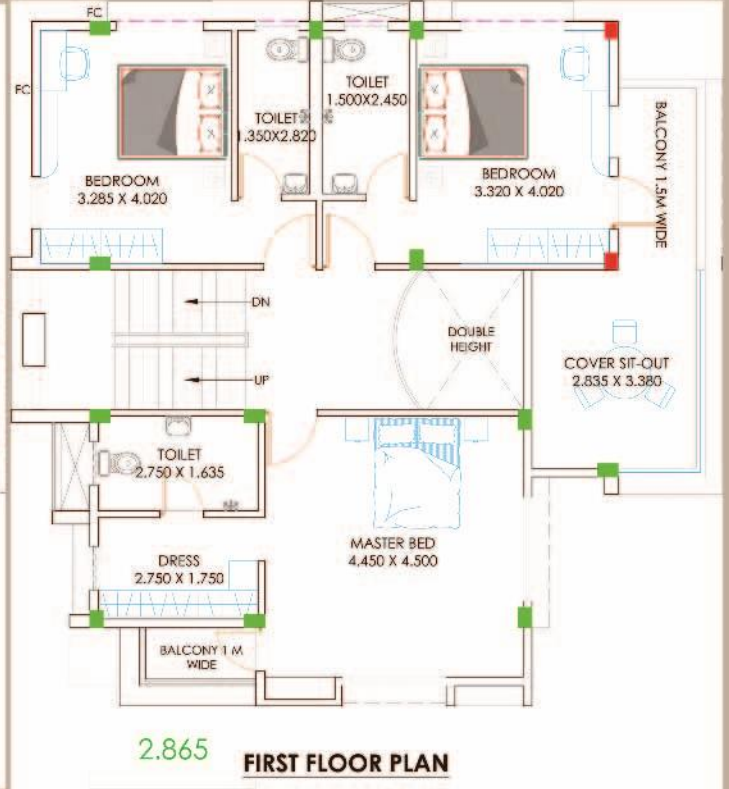

**Project:** Proposed Residence for Mr. Deepak Jha

**Client:** Mr. Deepak Jha

**Duration:** 16th April 2015 To 5th Dec 2015

**Location:** New Raipur

**Position:** Founder and Chief Architect Planner

**Project Detail:** Major role in the project is as follows-

- Survey Drawing.
- Submission Drawing.
- Structural Drawing
- Supervision services
- Concept Drawing .
- Building Plan and Elevation
- 3D View

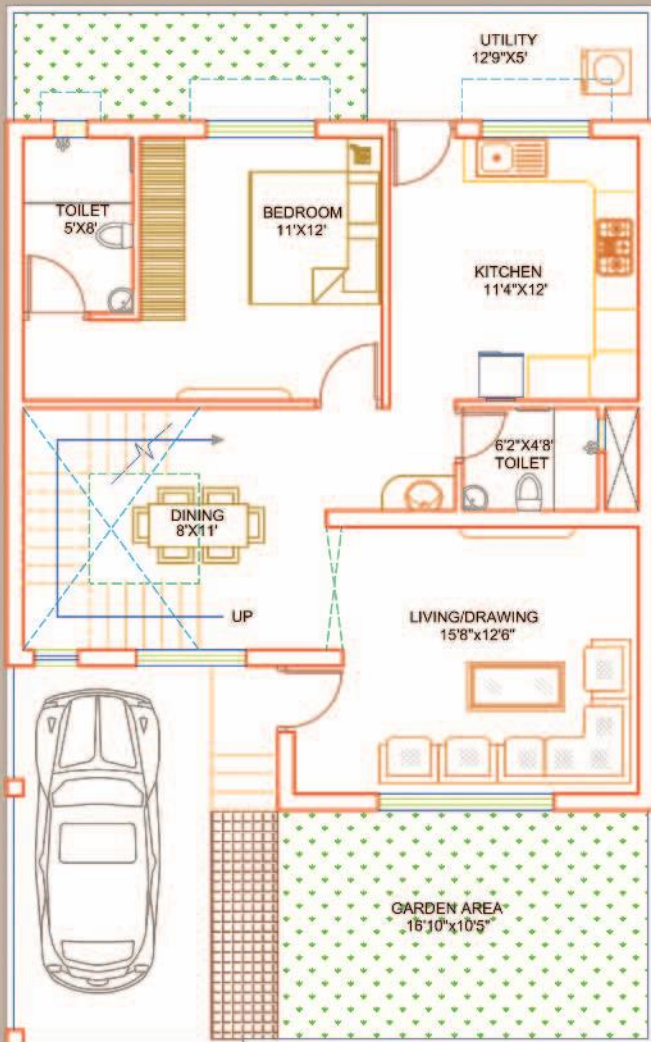

GROUND FLOOR PLAN

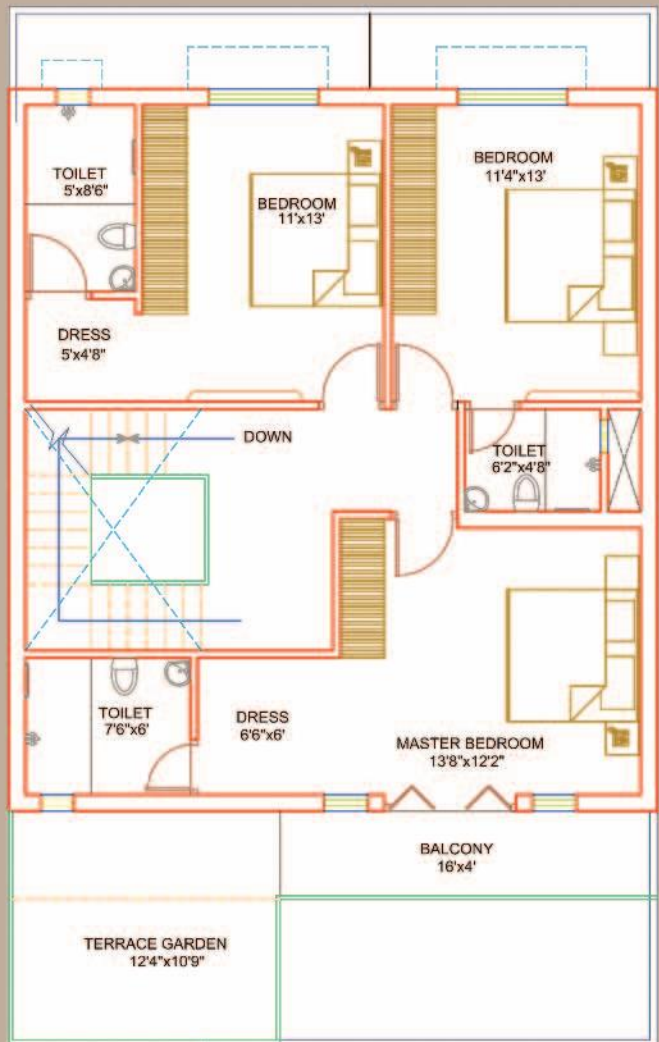

FIRST FLOOR PLAN



**Project: Residence**

Client: .

Duration: 27th Jun 2014 To 5th July 2016

Location: Durg

Position: Founder and Chief Architect Planner

**Project Detail:** Major role in the project is as follows-

- Survey Drawing.
- Submission Drawing.
- Structural Drawing
- Supervision services
- Concept Drawing .
- Building Plan and Elevation
- 3D View

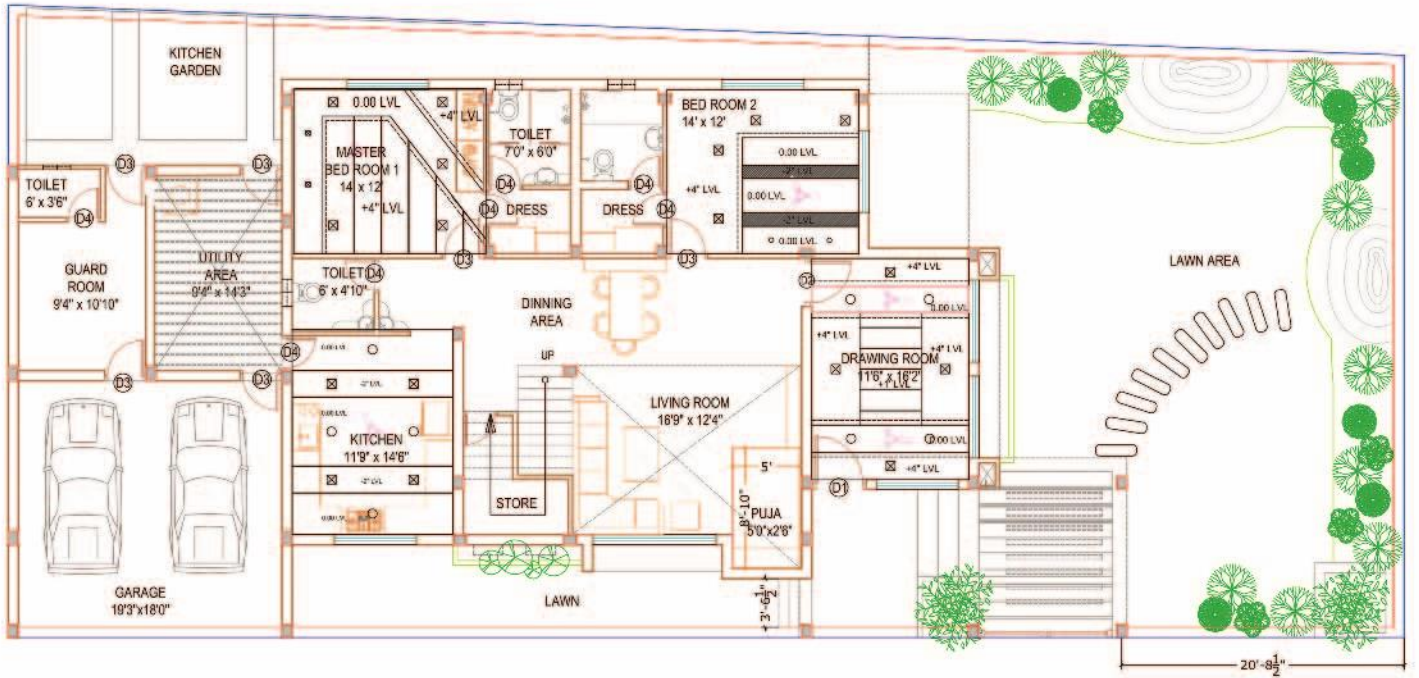

**Project:** Residence for Mr. Nayar

Client: Nayar

Duration: 19th April 2016

Location: Kerala

Position: Founder and Chief Architect Planner

**Project Detail:** Major role in the project is as follows-

- Survey Drawing.
- Submission Drawing.
- Structural Drawing
- Concept Drawing .
- Building Plan and Elevation
- 3D View

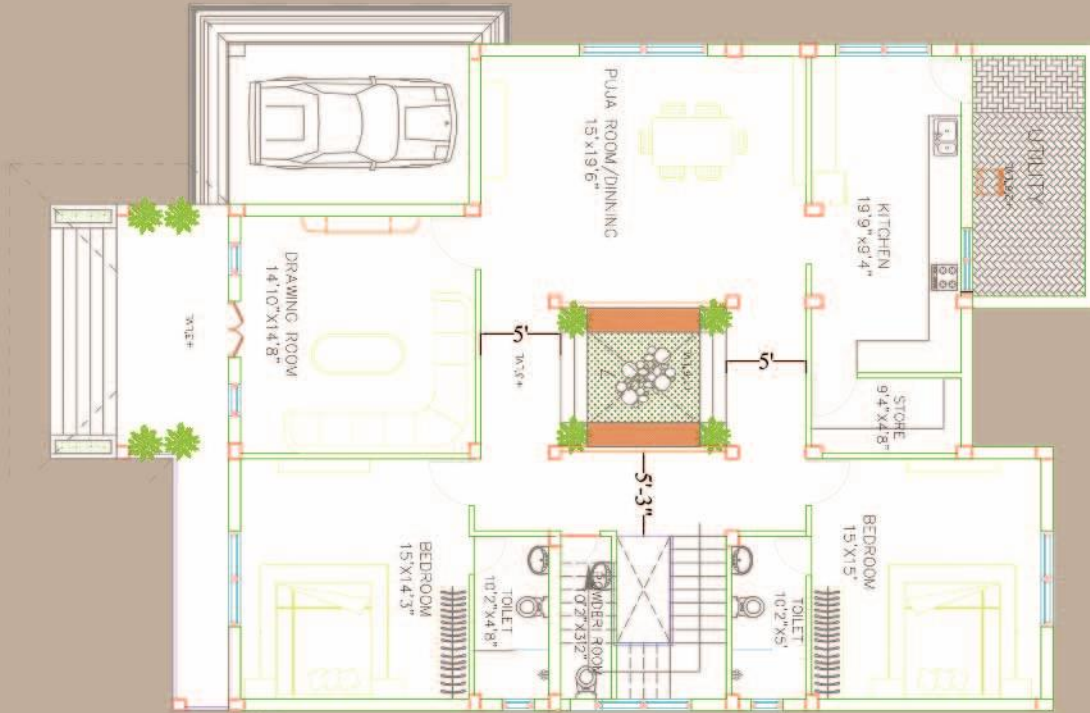

**Project: GARG APPARTMENT**

Client: M. Ravindraji Garg.

Duration: 19th Aug 2016

Location: Kotma

Position: Founder and Chief Architect Planner

**Project Detail:** Major role in the project is as follows-

- Survey Drawing.
- Submission Drawing.
- Structural Drawing
- Concept Drawing .
- Building Plan and Ellevation
- 3D View



VIEW



VIEW



PLAN



VIEW



VIEW

**Project: GARG APPARTMENT**

Client: M. Ravindraji Garg.

Duration: 19th Aug 2016

Location: Kotma

Position: Founder and Chief Architect Planner

**Project Detail:** Major role in the project is as follows-

- Survey Drawing.
- Submission Drawing.
- Structural Drawing
- Concept Drawing .
- Building Plan and Elevation
- 3D View



VIEW



VIEW



PLAN



VIEW



VIEW





**Project:** : Penthouse Restoration And Interior Design Work

**Client:** : Mustafa kithawala

**Location:** Nagpur, Maharashtra

**Duration:** 2023 - 2024

**Position:** Chief Architect and Planner

**Project Detail :**

**Major Role In Project :**

- Interior design services
- Architectural design services
- Supervision Services
- Concept Drawing
- Design build services
- 3D View



INTERIOR DETAILS- KITCHEN DETAILS FOR RESIDENCE OF KOTHAWALAS

DESIGNED BY JABCON CONSULTANTS RAIPUR

INTERIOR DETAILS- LIVING CUM DINING ROOM FOR THE RESIDENCE OF KOTHAWALAS

DESIGNED BY JABCON CONSULTANTS RAIPUR



**Project :** Muffadal Firework Office  
**Client :** Kadri Enterprises Family  
**Duration:** January 2022 - Ongoing

**Location:** Ahmed Colony, Akola  
**Position:** Chief Architect and Planner

**Project Detail :**

**Scope Of Work :** All Statutory Approvals On Behalf Of Client

**Major Role In Project :**

- Survey Drawing
- Submission Drawing
- Structural Drawing
- Supervision Services
- Concept Drawing
- Building Plan And Elevation
- 3D View



S.NO	DESCRIPTION	HEIGHT/MODULE
01	SWITCH FOR CELL CLIP	7' 100'
02	SWITCH FOR CELL CLIP	7' 100'
03	SWITCH FOR CELL CLIP	7' 100'
04	SWITCH FOR CELL CLIP	7' 100'
05	SWITCH FOR CELL CLIP	7' 100'
06	SWITCH FOR CELL CLIP	7' 100'
07	SWITCH FOR CELL CLIP	7' 100'
08	SWITCH FOR CELL CLIP	7' 100'
09	SWITCH FOR CELL CLIP	7' 100'
10	SWITCH FOR CELL CLIP	7' 100'
11	SWITCH FOR CELL CLIP	7' 100'
12	SWITCH FOR CELL CLIP	7' 100'
13	SWITCH FOR CELL CLIP	7' 100'
14	SWITCH FOR CELL CLIP	7' 100'
15	SWITCH FOR CELL CLIP	7' 100'
16	SWITCH FOR CELL CLIP	7' 100'
17	SWITCH FOR CELL CLIP	7' 100'
18	SWITCH FOR CELL CLIP	7' 100'
19	SWITCH FOR CELL CLIP	7' 100'
20	SWITCH FOR CELL CLIP	7' 100'
21	SWITCH FOR CELL CLIP	7' 100'
22	SWITCH FOR CELL CLIP	7' 100'
23	SWITCH FOR CELL CLIP	7' 100'
24	SWITCH FOR CELL CLIP	7' 100'
25	SWITCH FOR CELL CLIP	7' 100'
26	SWITCH FOR CELL CLIP	7' 100'
27	SWITCH FOR CELL CLIP	7' 100'
28	SWITCH FOR CELL CLIP	7' 100'
29	SWITCH FOR CELL CLIP	7' 100'
30	SWITCH FOR CELL CLIP	7' 100'
31	SWITCH FOR CELL CLIP	7' 100'
32	SWITCH FOR CELL CLIP	7' 100'
33	SWITCH FOR CELL CLIP	7' 100'
34	SWITCH FOR CELL CLIP	7' 100'
35	SWITCH FOR CELL CLIP	7' 100'
36	SWITCH FOR CELL CLIP	7' 100'
37	SWITCH FOR CELL CLIP	7' 100'
38	SWITCH FOR CELL CLIP	7' 100'
39	SWITCH FOR CELL CLIP	7' 100'
40	SWITCH FOR CELL CLIP	7' 100'
41	SWITCH FOR CELL CLIP	7' 100'
42	SWITCH FOR CELL CLIP	7' 100'
43	SWITCH FOR CELL CLIP	7' 100'
44	SWITCH FOR CELL CLIP	7' 100'
45	SWITCH FOR CELL CLIP	7' 100'
46	SWITCH FOR CELL CLIP	7' 100'
47	SWITCH FOR CELL CLIP	7' 100'
48	SWITCH FOR CELL CLIP	7' 100'
49	SWITCH FOR CELL CLIP	7' 100'
50	SWITCH FOR CELL CLIP	7' 100'

LEGEND  
 [Symbol] CEILING LIGHT (10.5.0)  
 [Symbol] SPOT LIGHT  
 [Symbol] PVC AT THE WALL CROWN  
 [Symbol] CEILING FAN

FALSE CEILING PLAN  
 ELECTRICAL PLAN

FIREWORKS BOOKING OFFICE KADRI ENTERPRISES AKOLA (MH) | FALSE CEILING WORKING DRAWING | 07 DEC 2022 | JABCON CONSULTANTS

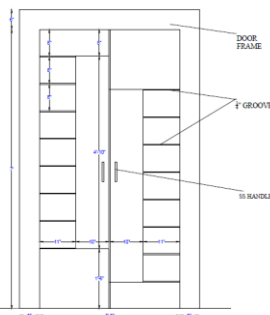
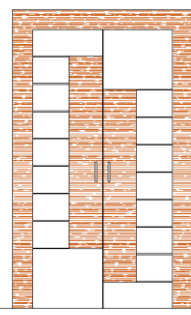
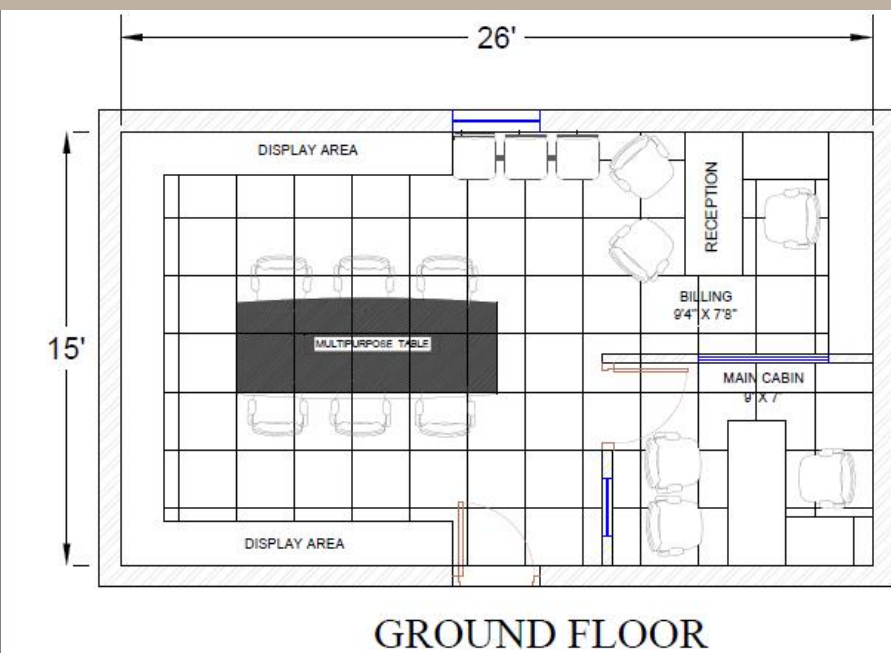

NOTE - WORKING DRAWING WILL BE WORKED ON ONCE THE CONCEPT DESIGN IS APPROVED.

**Project: Interiors For Presswala Corporate Office**

**Client: Jawed Bhai Presswala**

**Duration: August – January (2016)**

**Location: Chotapara, Raipur (C.G)**

**Position: Chief Architect And Planner**

**Project Detail :**

**Major Role In Project : - Total Design Build Interior work**

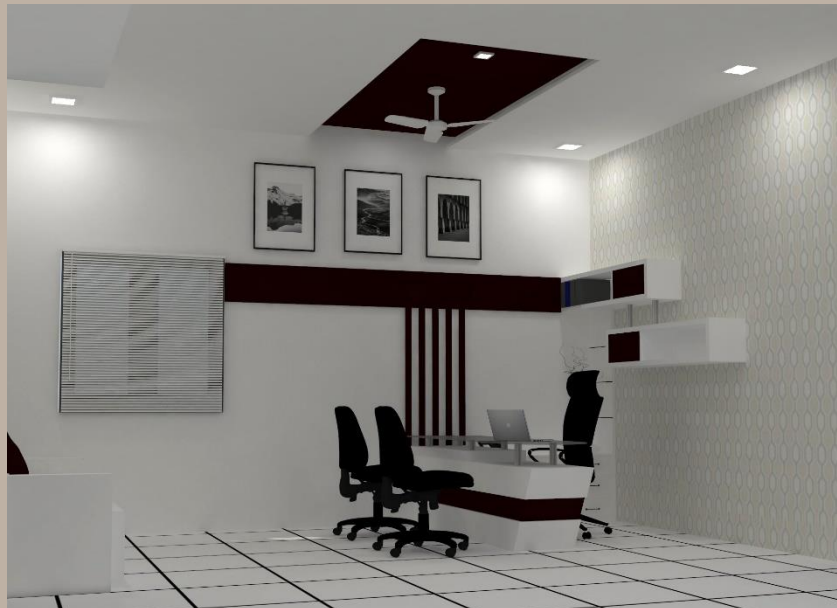
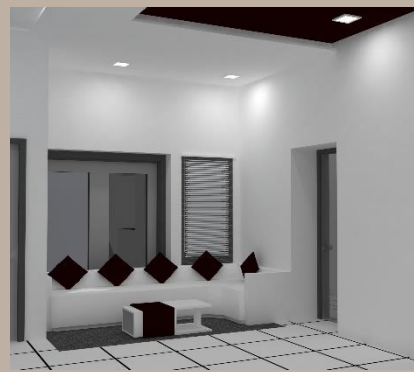
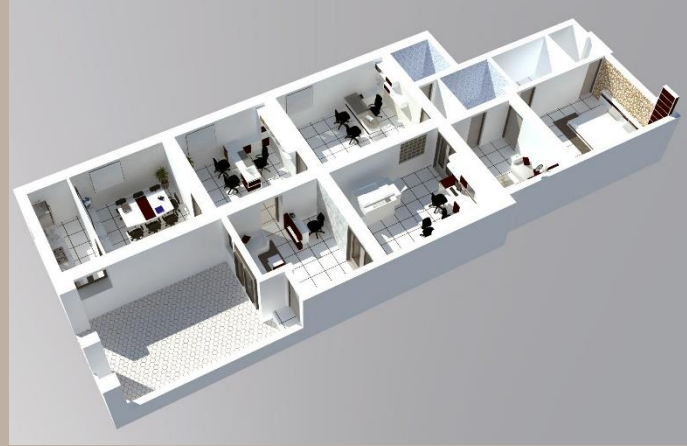
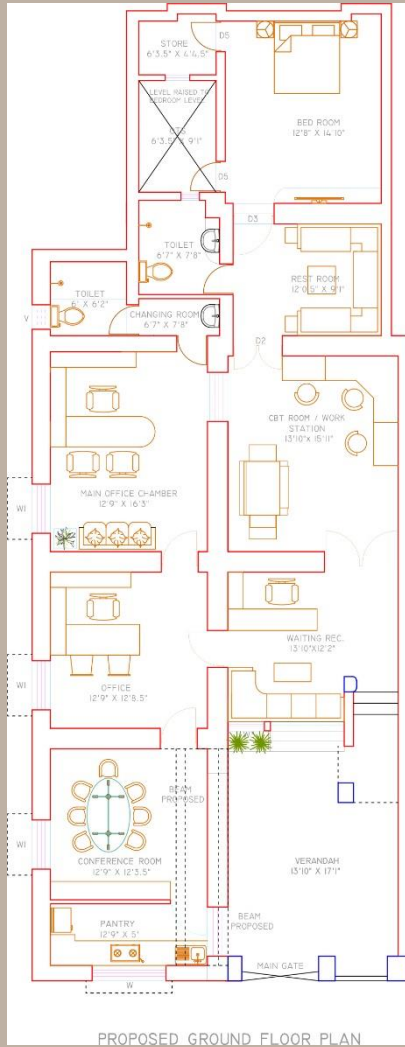

**Project: Ahmedji Bhai -Paint Shop**

Client: Mr. Ahmedji bhai

Duration: 13th Jan 2015 to 2nd Jun 2016

Location: Raipur

Position: Founder and Chief Architect Planner

**Project Detail:** Major role in the project is as follows-

- Interior Design .
- Lighting Plan.
- 3D View
- Supervision services
- Service Drawing
- Furniture Layout &Details

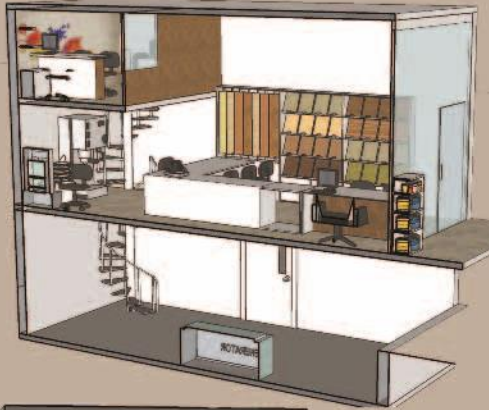
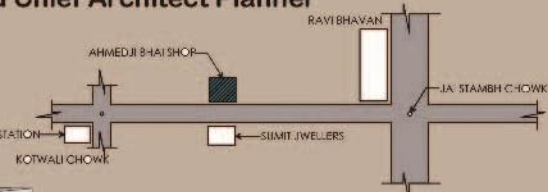

**Project: Siddhi Vinayak Saree Showroom**

Client: Mr. S.D.Agrawal

Duration: 20th Feb 2015 to 22nd May 2015

Location: Raipur

Position: Founder and Chief Architect Planner

**Project Detail:** Major role in the project is as follows-

- Interior Design.
- lighting plan.
- furniture layout & details
- Supervision services
- Service Drawing
- 3D View

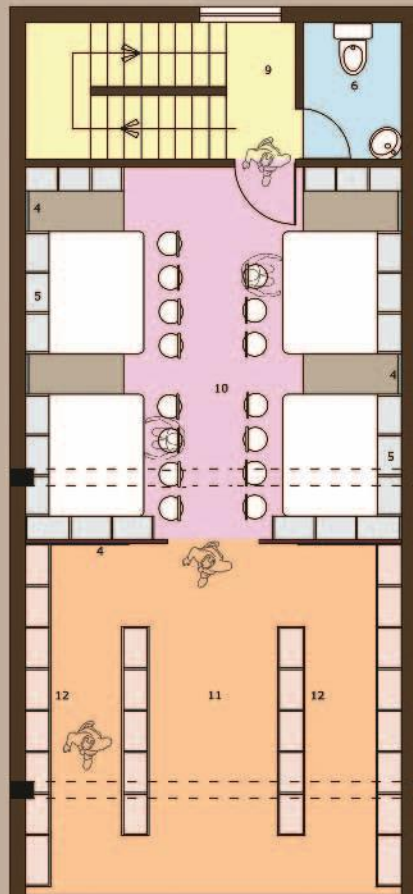
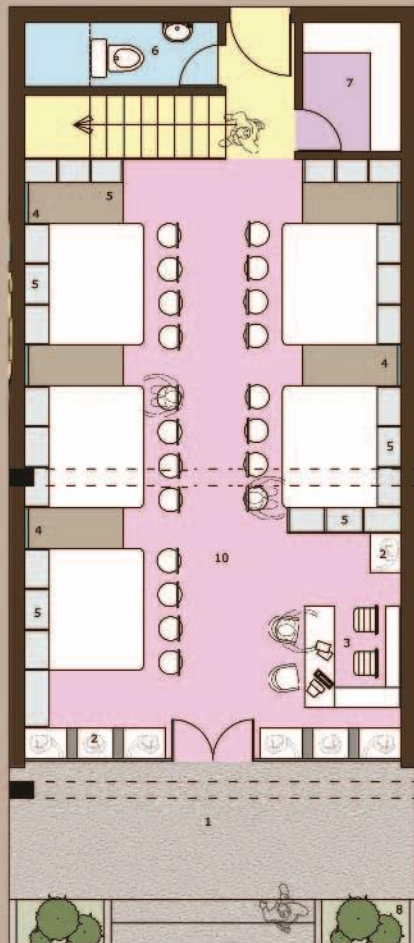

**Project: Pune Residence.**

Client: Mr. Shabbir

Duration:

Location: Pune

Position: Founder and Chief Architect Planner

**Project Detail:** Major role in the project is as follows-

- Interior Design .
- Lighting Plan.
- 3D View.
- Supurvision Drawing.
- Service Drawing.
- Furniture layout & Details.



View



View

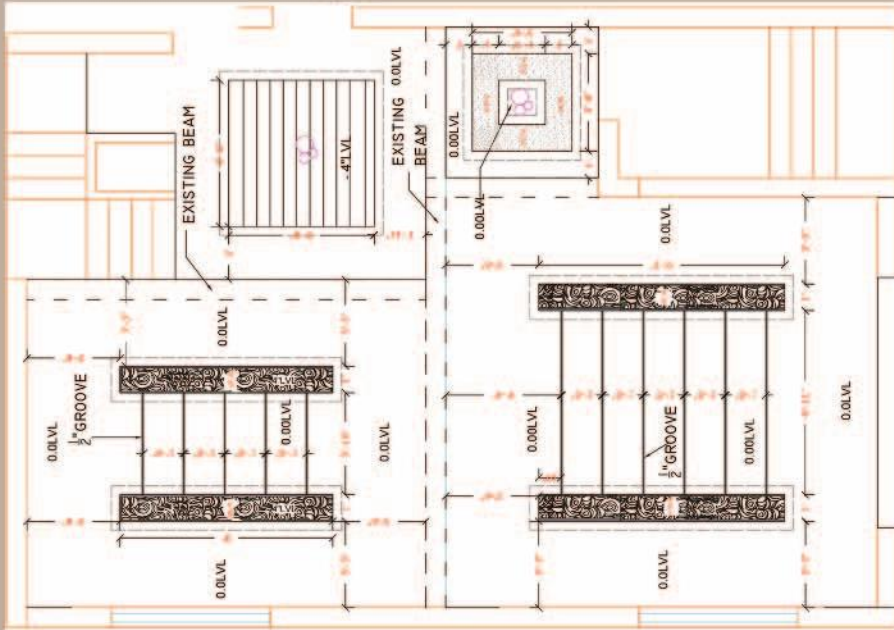

WORKING DRAWING



WORKING DRAWING



View

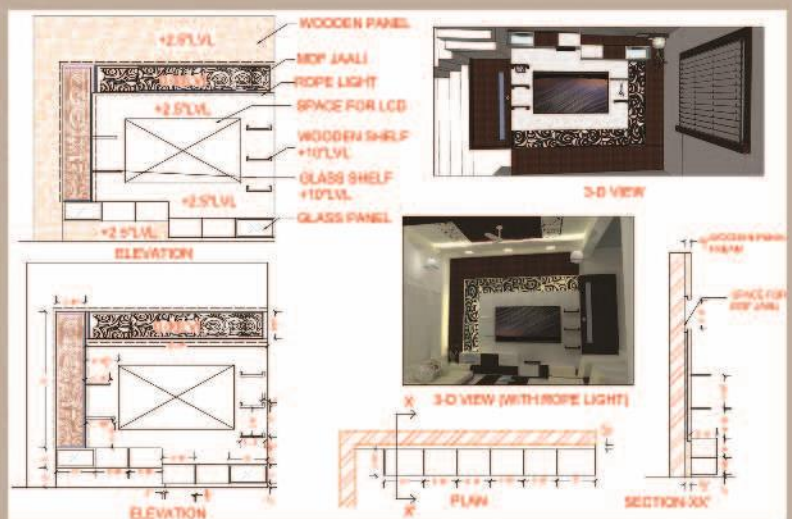

WORKING DRAWING

**Project:** Durg Residence.

**Client:** Mr. Kishanji Burman

**Duration:** 15th oct 2015

**Location:** Durg

**Position:** Founder and Chief Architect Planner

**Project Detail:** Major role in the project is as follows-

- Interior Design .
- Lighting Plan.
- 3D View.
- Supurvision Drawing.
- Service Drawing.
- Furniture layout & Details.



**Bed Room**



**Living Room View**



**Master Bed Room working Plan**

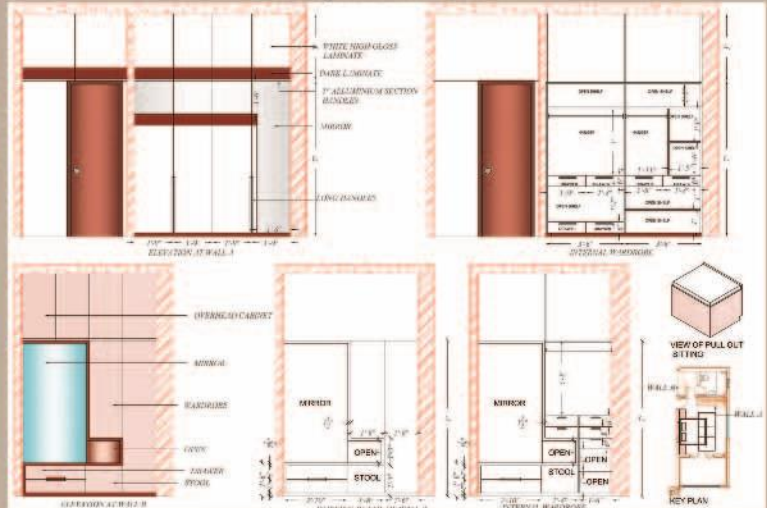

**Master Bed Room View**



**Master Bed Room View**



**Project:** NTPC Guest House Interior Design at Lara Thermol Power Plant Township , Raigarh

**Client:** NTPC

**Location:** Lara, Raigarh

**Position:** Chief Architect Planner

**Description of Project:**

- Interior Design & Planning
- Electrical Design & HVAC Design
- Fire Fighting Design
- Detail BOQ & Estimate
- Site Supervision & Quality Reporting



EXISTING SITE OF RECEPTION AREA



PROPOSED DESIGN OF RECEPTION AREA

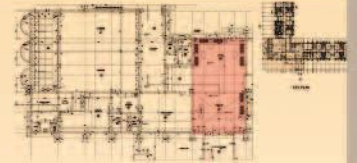

KEY PLAN



SECTION AT A-A'



3-D VIEW A'

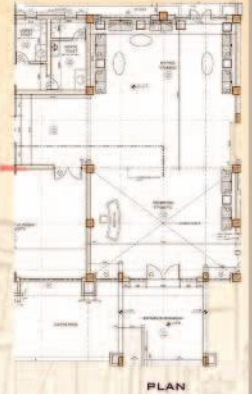

PLAN



SECTIONAL VIEW



PROPOSED RECEPTION AREA



EXISTING SITE OF RECEPTION AREA



PROPOSED VIEW OF LOUNGE



KEY PLAN



SECTION A-A'



A'

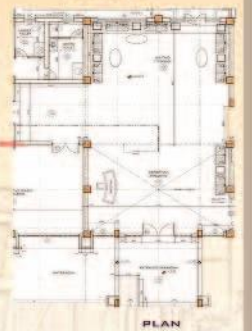

PLAN



PROPOSED VIEW OF LOUNGE



PROPOSED VIEW OF LOUNGE

**Project:** Mr. Ashutosh

**Client:** Mr. Ashutosh

**Duration:**

**Location:** Kotma

**Position:** Founder and Chief Architect Planner

**Project Detail:** Major role in the project is as follows-

- Interior Design .
- Lighting Plan.
- 3D View.
- Supurvision Drawing.
- Service Drawing.
- Furniture layout & Details.

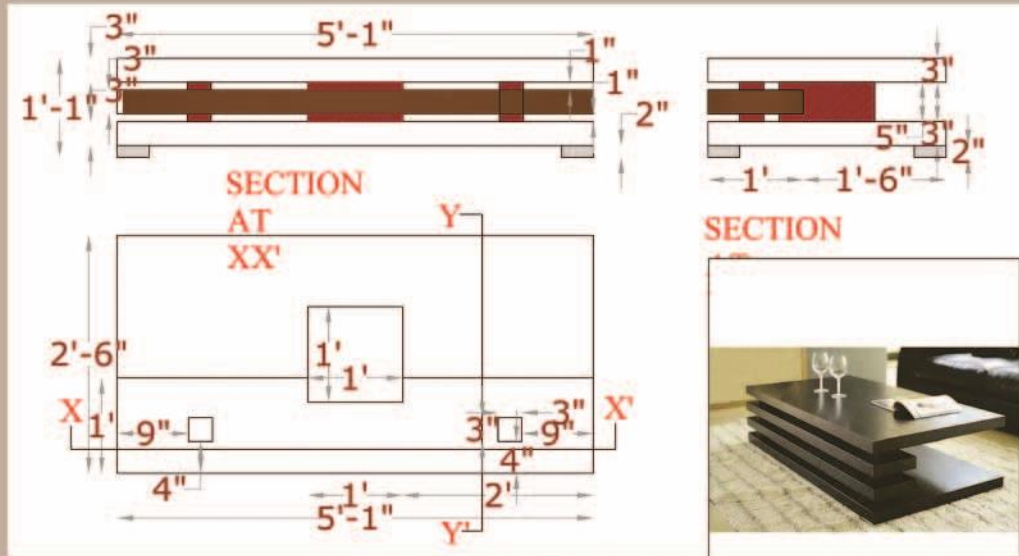

Working \_ Center Table

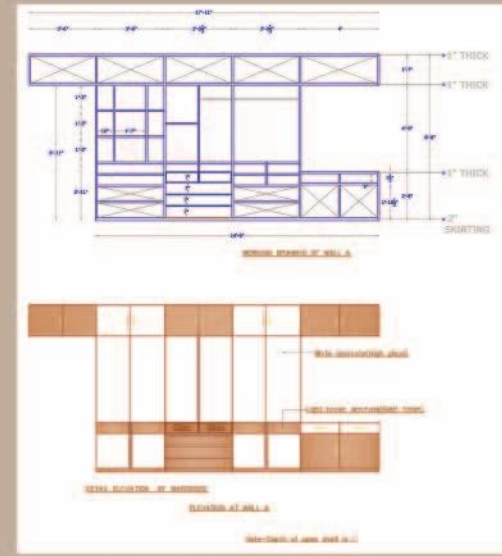

Working \_ Wardrode

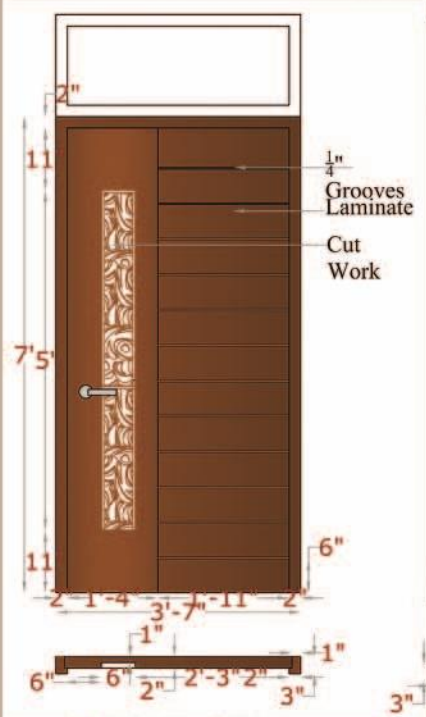

Working \_ Door

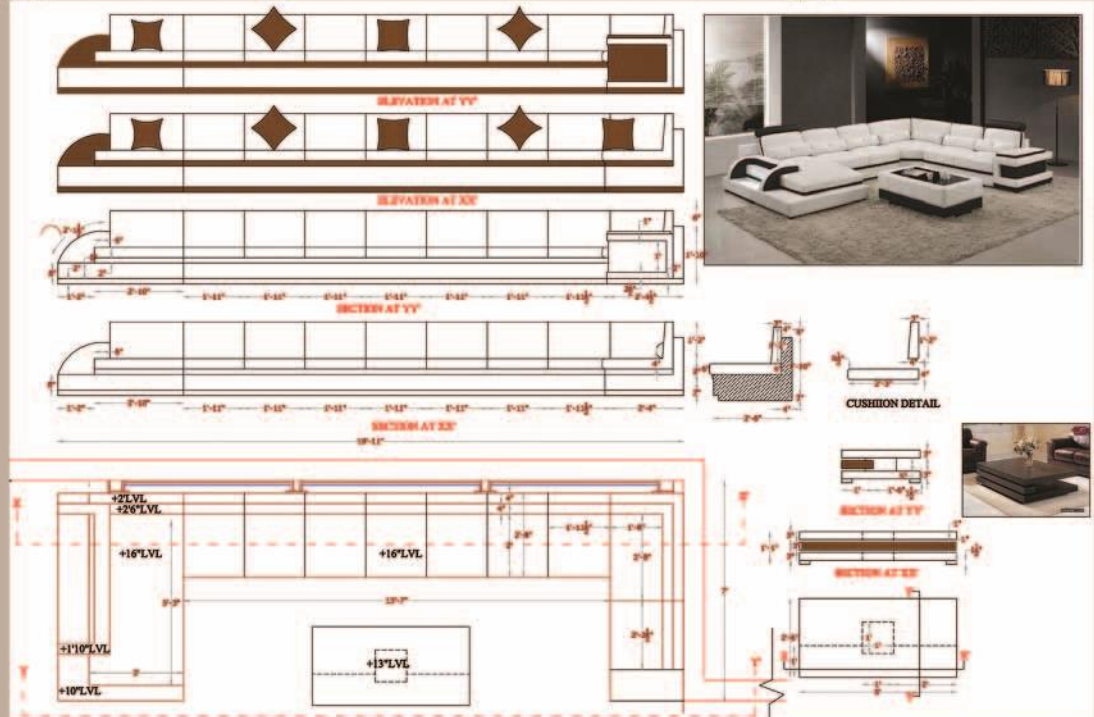

Working \_ Sofa

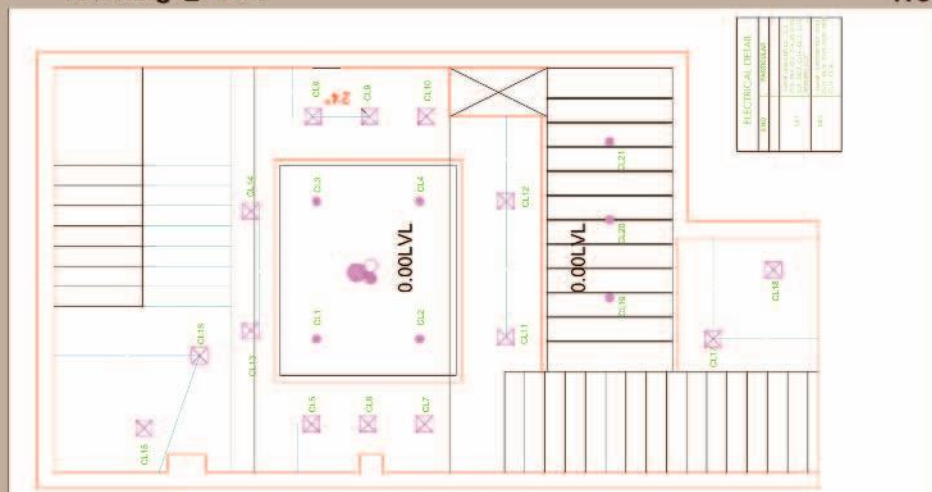

Electrical plan

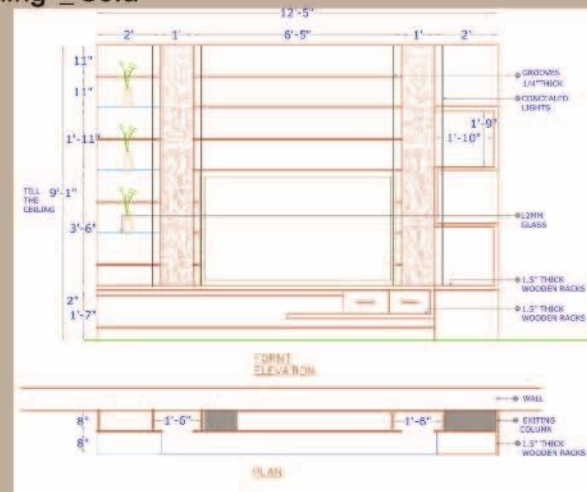

Working \_ T.V Unit



**Project:** International Workshop for sustainable Architecture at Reunion Island- selected from CEPT to represent India in the workshop which was represented by students of 31 countries in Asia  
**Sponser :** French Government  
**Location:** Reunion Island  
**Duration:** May 2004

**Description of workshop:** The workshop aimed to bring awareness about sustainable material and planning for sustainable Architecture. A naturusque site was chosen in village Hell Bourg having an existing ruin in the site and they laid an exploded house concept in that site. Different parts of the house was break down to designing a living room, Master Bedroom, Children's bedroom, Kitchen, Living room, Toilets, front loft and back loft of a house and they expected Designing and construction on the site from the groups. Freedom of choice of selection your place in the site to selection of materials for construction was left to the individual group. Eight groups were made of five each and five members of a group were made from different countries each, so they learn to work in a group, better interaction, s haring cultures, sharing experiences, which leads to firm a contemporary global architecture. The best work in workshop is displayed here of the group who has designed a loft in the house

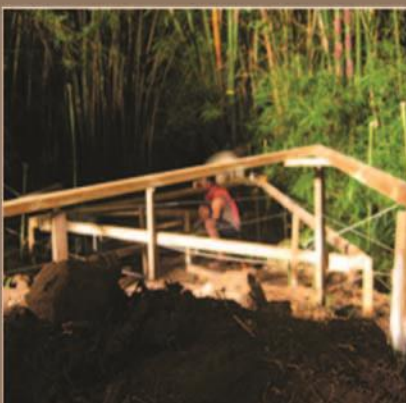
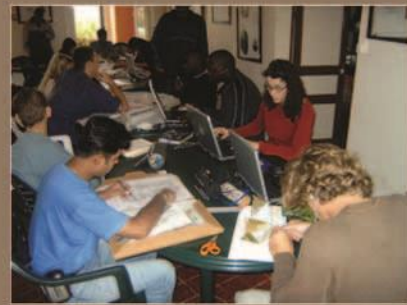
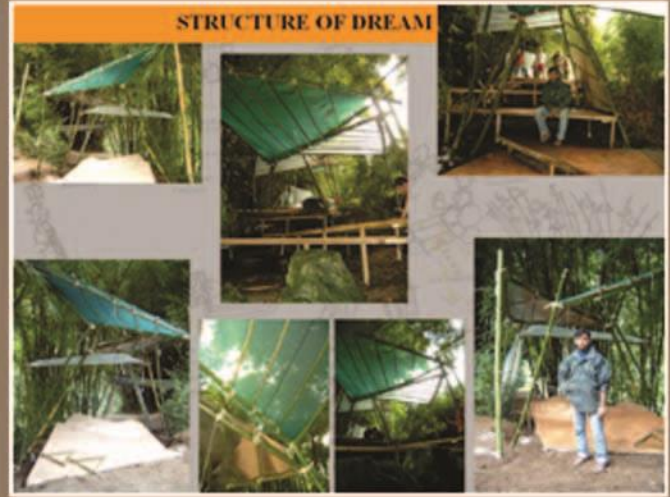
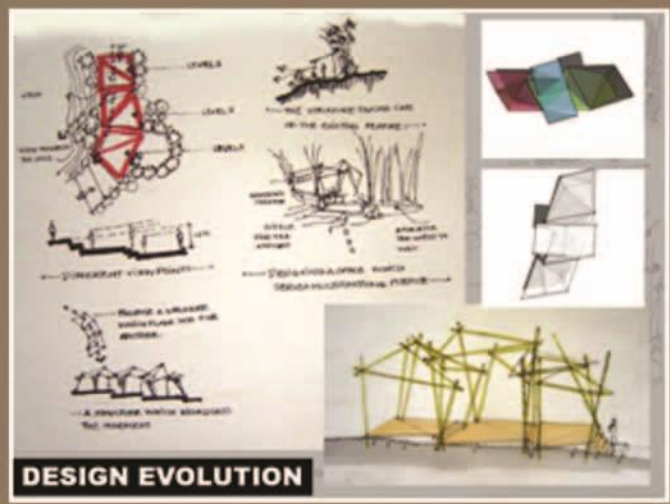

## Interior Projects

### Private Clients

- Interior design for Corporate office of NTPC, Raipur(client – NTPC-Project cost 1.2 Crores)
- Interior design for 5 bedroom residence at Byron Bazaar (client –Mr Dinesh Tapadia – project cost 28 Lakhs)
- Interior design for 2 bedroom Apartment for Diamond Merchant (client – Mr Happu Baid – project cost 8.5 Lakhs)
- Interior design for 4 bedroom residence at Devendra Nagar, Sec 1, Raipur(client – Mr Monu Agrawal – Project cost 12 Lakhs)
- Interior design for Architects Office(Cient-Mr Mustufa Ahmed-Project cost 9.5 Lakhs)
- Interior design for imitation jewellery shop, Baijnath Para, Raipur (client- Mr Happu Baid- Project cost 4.5 Lakhs)
- Interior design for a Book dealer shop at Malviya Road, Raipur(Client- Supreme Book shop- Project cost 8.5 Lakhs)
- Interior design for an Accounts professional at Geeta Nagar, Raipur(client- Mr Sahid Bhai- Project cost – 7.5 Lakhs)
- Interior design for saree shop at mahalaxmi market, Raipur(client – Agrawal ji-Project cost 60 lakhs)
- Interior design for CA residence at Devendra Nagar, Raipur (Client – Mr Sharad Khandelwal- Project cost 18 Lakhs)
- Interior design for Rice mill owner at Geeta Nagar Raipur(client- Mr Ghanshyam Khandewal – project cost 25 Lakhs)
- Villa interiors at Wallfort City, Raipur (client- Mr Gulab Agrawal – Project cost 25 Lakhs)
- Interior design services for Cloth shop owner at Dolphin, Moha, Raipur- Porject cost 16 Lakhs)
- Interior design of residence of Chemical dealer (client – Mr Juzer Kapasi – project cost 8.5 Lakhs)
- Interior design for office for Jewellery making (Client- Mr Hakim Kapasi – Project cost 3 lakhs)
- Turn key design & implementation of 3 bedroom flat at Byculla, Mumbai (Client Mr usuf Nulwalla- Project cost 15 Lakhs)
- Design services for CA's firm name Partner tree at Amboli, Andheri, Mumbai(client- Mr Sayeed- Project cost 9 Lakhs)
- Design services for 2 bedroom Flat at Marol Mumbai(client – Mr Dr Murtuza- Project cost 4.5 Lakhs)
- Design & supervision services for a 5 bedroom old house at Akola(client – Mr Ahmed Bhai- Project cost 18 Lakhs)

## Urban Planning Projects

### Project Feasibility

- Housing Feasibility study for Barapathher site(4 acres), Barapatthar, Seoni (client- Mr Raghuveer Singh Bedi- Project cost 5.6 crores)
- Feasibility study for railway land put for PPP by RLNDA, Bhilai(client – Ashoka Infrastructure Pvt Ltd-Project cost 55 Crores)
- Feasibility study for an amusement Park project at Naya Raipur

### Bid Process Management

### Landscape Projects



# University Of Pune

(Formerly  
University of Poona)



*We, the Chancellor,  
the Vice Chancellor and  
the Members of the Management Council  
and the Academic Council of the  
University of Pune certify*

*that Ahmed Mustafa Jameel  
of B.K.P.S. College of Architecture,  
Pune*

*having been examined and found duly qualified for  
the degree of*

## **Bachelor of Architecture**

*and placed in the Higher Second Class  
in May 2003.*

*The said degree has been conferred on him.*

*In testimony whereof is set  
the seal of the said University.*

*26th December 2003*

EN -5616

*A. S. Kulkarni.  
Vice-Chancellor*





Membership No./  
Registration No.

846093409



INDIAN  
INSTITUTE OF  
BANKING & FINANCE

Sr. No. 25

## *Certificate of the Institute*

*The Governing Council of Indian Institute of Banking  
& Finance do hereby certify  
that*

**MUSTUFA AHMED**

*has successfully completed the prescribed course  
of studies and passed the  
IIBF-IFMR Project Finance  
examination of the Institute.*



MUMBAI, DATED 14TH SEP 2011

ISSUED IN PURSUANT TO CLAUSE 3 (c) OF  
THE MEMORANDUM OF ASSOCIATION OF  
THE INSTITUTE

**R. BHASKARAN**  
CHIEF EXECUTIVE OFFICER  
FOR AND ON BEHALF OF  
THE GOVERNING COUNCIL

  
DIRECTOR OF EXAMINATIONS

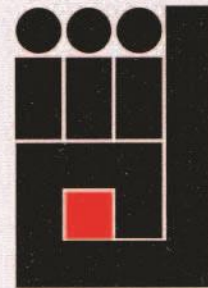

INSTITUTE  
OF INDIAN  
INTERIOR  
DESIGNERS

This is to certify that  
Mr. Ahmed Mustafa  
has been elected as  
**ASSOCIATE MEMBER**

of Institute of Indian Interior Designers

(An Association constituted in 1972 to promote and co-ordinate in the public interest  
the development of The Art, The Science and The Practice of Interior Design.)

In witness where of the said institution has  
caused its Common Seal to be affixed  
This 8<sup>th</sup> day of May, 2010



AM-3515

VALID UPTO 2011

Chairman  
Membership Committee

Hon. Secretary - IIID

President - IIID

This Certificate is the property of the Institute of Indian Interior Designers.



# JABCON CONSULTANTS

---

Master Planning/Urban planning

---

Architecture

---

Real Estate advisory

---

Interior Design

---

Project Management

---

Bid process Management

---

Sustainable Design

**Head Office - JABCON CONSULTANTS, C/O**  
Progressive Point, 3<sup>rd</sup> Floor Off No. 318  
Near Whole Sale Fruit Market, New Dhamtari Road,  
Raipur (C.G) , 492001  
+91-8120022552

**Project office - C/O Hakimi Arcade,**  
3<sup>rd</sup> Floor Off No. 301 OCM Chowk  
Raipur, (C.G), 492001

**Project office - C/O Silver tower, First Floor,**  
Deepak Chowk, Akola (M.H) 440001

**Website-**[www.jabconconsultants.in](http://www.jabconconsultants.in)  
**Email-**[jabconconsultants@gmail.com](mailto:jabconconsultants@gmail.com)  
**-mustufa3@gmail.com**